



Product Manual

Forms

Financial

Promotional

Apparel

Simplifying Business, Maximizing Success

Statement of Confidentiality

The information contained in this document is confidential and/or privileged. It contains trade secrets and information that is company sensitive, proprietary, and confidential, the disclosure of which would provide a competitive advantage to others. As a result, this document shall not be disclosed, used, or duplicated, in whole or in part, for any purpose other than that of Ennis and its authorized distributors.

Copyright 2002-2005 Ennis, Inc. All rights reserved.



TABLE OF CONTENTS

Ennis Business Forms, Inc. produces one of the most complete business forms product lines of any manufacturer selling to the distributor market today. The Ennis Product Manual helps you understand and sell the full Ennis product line.

Separated by product, Product Manual pages consist of a definition of each Ennis product line and the basic features available for the product. Illustrations on the Product Pages show you standard features of the product and special features you can use to personalize your customers' forms. Product line features may differ from facility to facility. Please call the Ennis facility nearest to you to clarify availability.

Used as a reference book, the Ennis Product Manual gives you basic knowledge of each Ennis product, making it easier for you to be educated on our numerous product lines and various Ennis facility locations, plus more profits for you from the sales of our printed business products.

ALPHABETICAL INDEX OF PRODUCT PAGES

| | |
|---|--------------|
| Advertising Specialties | 23 |
| Awards and Ribbons | 24 |
| Banners | XX |
| Books, Scratch Pads | 8-9 |
| Business Forms & Supplies | 14-15 |
| Color Worx | XX |
| Commercial Printed Products | 28 |
| Continuous Forms | 4-5 |
| Continuous Letterhead | 6 |
| Cut Sheet Singles | 7 |
| Financial Forms | 29-30 |
| General Information & Policies | 32-40 |
| Guest Checks | 10-11 |
| Labels | 20-21 |
| P.O.P Displays | XX |
| Post-it[®] Notes | 26-27 |
| Presentation Products | 25 |
| Register Forms | 12-13 |
| Screen Printed Products | 22 |
| Snap-A-Part Unit Sets | 2-3 |
| Software Compatible Checks & Forms | 16-17 |
| Supplies & Accessories | 31 |
| Tags | 18-19 |

Snap-a-parts are multi-part forms bound in one common stub to form a unit. Snap-a-part unit sets are available carbon interleaved or carbonless. If carbon interleaved, the carbons are short opposite the stub to allow easy extraction of the individual parts from the stub. Your customers will often refer to them as “Snaps, Snap Forms or Snap-A-Parts.”

Form Measurement

The common stub may be at the top, bottom, left or right of the form. The stub width measurement determines which press the form is run on and should always be measured parallel to stub perforation. Forms presses require 1/4" lock up with no printing, on two sides, at right angle to the stub. Shaded areas on illustrations show 1/4" lock up areas.

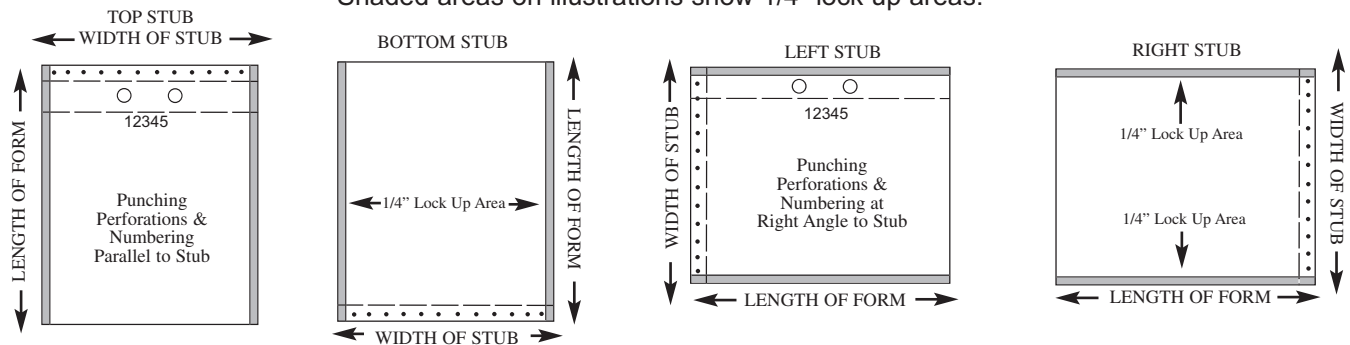

Available Features:

- Basic Form Widths** 3½", 3¾", 3⅞", 4¼", 5½", 5¾", 7", 7⅛", 8½", 11"
(Stub widths may be trimmed to intermediate sizes.)
- Basic Form Lengths** 6⅞", 7⅞", 9⅞", 11⅞", 14⅞", 16", 17½", 24"
- Number of Parts** 2 through 12
- Paper** 12, 15 or 20 lb. bonds. Carbonless papers. Additional papers available including ledgers, safety and tag stocks.
- Carbon** Blue for handwritten forms; black for machine written forms. Stripe coated and pattern carbons available.
- Ink** 1, 2 and 3 color front. 4-color front available from some plant locations. Back printing is considered one color and limits the front to three colors. Match inks.
- Composition** Part to part changes. Allowances given for camera-ready art, or negatives furnished on a plant by plant basis. Allowances given for exact repeat orders.
- Numbering** Press numbering on all parts or (crash) numbering. Ion Dep and barcodes are available at some facilities.
- Perforation** Right angle or parallel to stub.
- Punching** Press punching through paper parts only. Bindery drilling, through all parts and carbons. Both available at right angle or parallel to stub.
- Construction** All parts glued in one common stub. Snap forms can have a second stub if necessary.
- Binding In Books** Forms can be bound in tag fly, wrap-a-round or triad covers.

TAG FLY BINDING

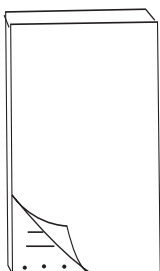

WRAP-A-ROUND BINDING

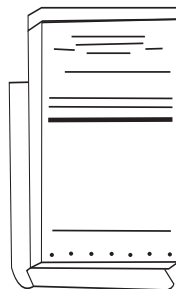

TRIAD BINDING

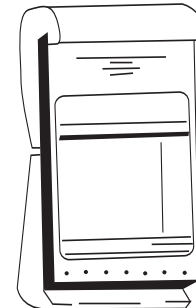

Quantities 1,000 to 100,000. Larger quantities available.

Manufacturing Locations To be connected to the nearest manufacturing location, please contact the Ennis HOTLine at (800) 972.1069.

SNAP-A-PART UNIT SETS



Snap-a-part unit sets may be printed with any average composition your customers want on the face of the form. Personalize your customers' snap-a-part unit sets with special features available from Ennis. Composition features dress your customers' forms up, while construction features make the forms more functional.

5/8" stub, with lineholes is standard. Binding stub may be at top, bottom, left, or right of form.

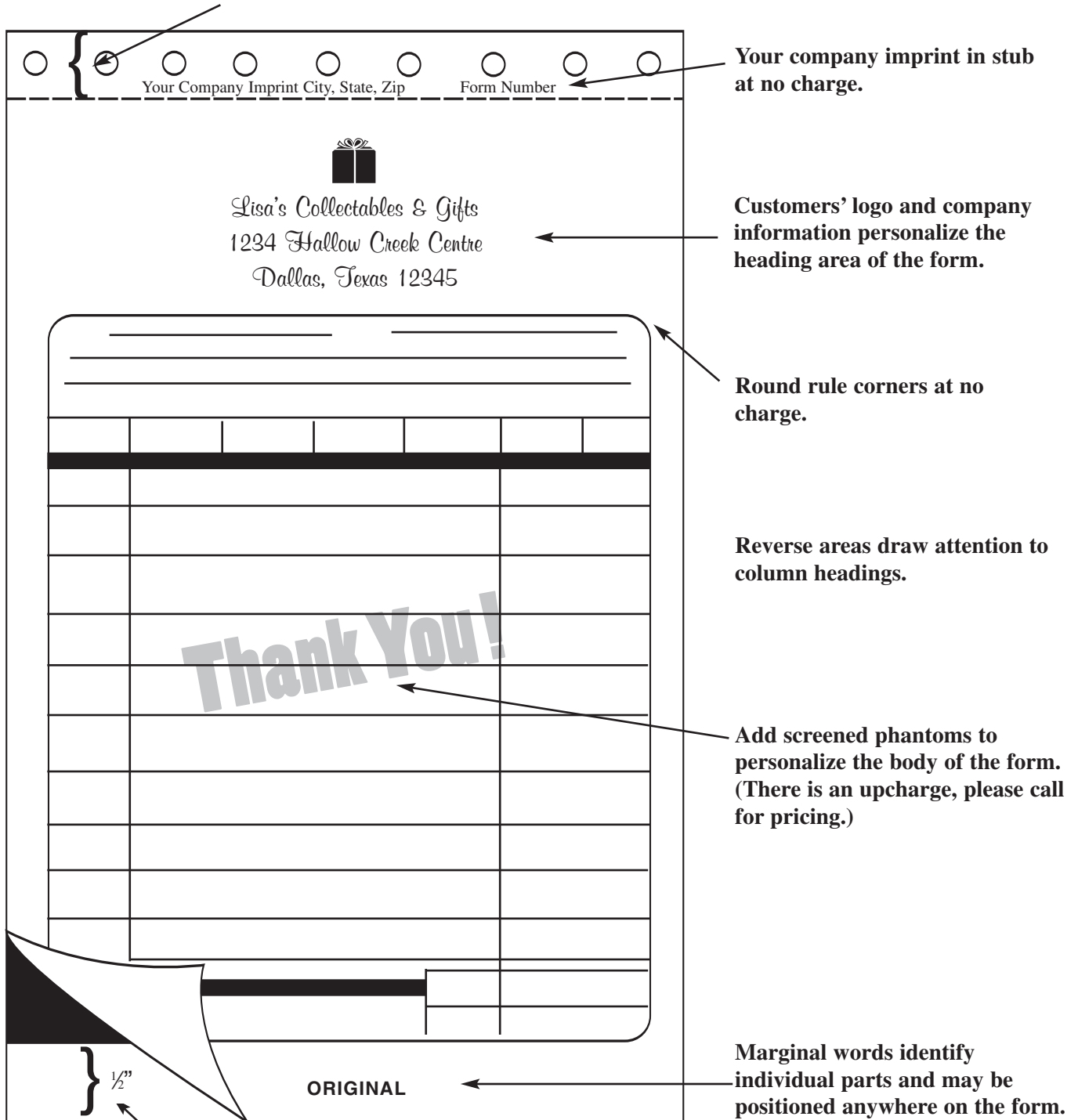

Standard carbon length, 1/2" shorter than paper parts, should cover last writing line. Carbonless forms may be printed in this 1/2" area.

Continuous Forms are single or multi-part forms produced as a continuous web with only perforations between forms, not cut into individual units. Continuous Forms can be run as carbon interleaved or carbonless forms. These forms will have margins on the left, right or both to allow for fastening of the parts together with crimping or gluing.

Form Measurement Continuous forms are first measured, left to right, full width of the form, including the margins. Continuous form presses require 1/4" lock up with no printing at top and bottom, at right angles to the margins. Shaded areas on illustrations show 1/4" lock up areas.

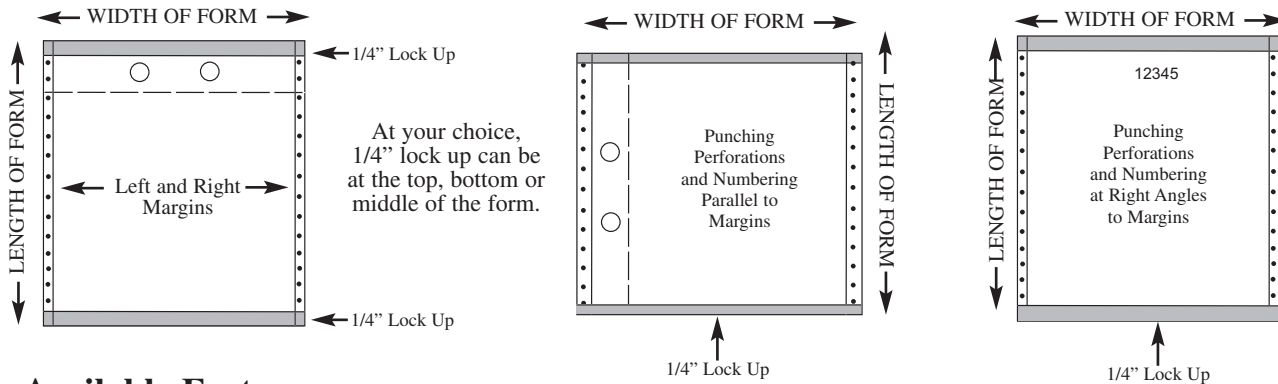

Available Features:

- Basic Form Widths** 4", 8", 8-1/2", 9-1/2", 9-7/8", 10-5/8", 11-3/4", 12-27/32", 13-5/8", 14-7/8", 16-3/4"
(Width of form may be trimmed to intermediate sizes.)
- Basic Form Lengths** 3-1/2", 3-2/3", 4", 4-1/4", 5-1/2", 6", 6-1/2", 7", 7-1/3", 8", 8-1/2", 11", 12", 14", 17", 22"
- Number of Parts** 1 through 8
- Paper** 12, 15 or 20-lb. bonds. Carbonless papers. Additional papers include ledger, safety, tag stocks, and security papers.
- Carbon** Black for machine written forms. Blue available at an upcharge. Stripe coated and pattern carbons available.
- Ink** 1, 2 or 3 color front, on some sizes, 4-color can be done. Back printing is considered one color and reduces the number of colors by one. Match inks.
- Composition** Part to part changes. Allowances given for camera-ready art or negatives furnished on a plant by plant basis. Allowances given for exact repeat orders.
- Numbering** Press numbering on all standard parts or (crash) numbering. MICR numbering on checks. Ion Dep, (consecutive barcode and large numbers) available.
- Perforation** 1/2" marginal perforations are standard and may be moved in or out or eliminated at no charge. Additional perforations, at right angle or parallel to margins are available at an upcharge.
- Punching** Through paper parts at right angle or parallel to margins.
- Construction** Forms may be fastened in one or both margins using standard crimping (small cuts in the paper that punch through the other parts to hold them together), line or spot gluing.
- Breaks In Cases** Breaks in continuous forms are flagged on outside of cartons. Contact Customer Sales when repair of breaks is required.
- Quantities** 1,000 to 100,000. Larger quantities available. A 250 quantity minimum can be done on some 11" forms.
- Manufacturing Locations** To be connected to the nearest manufacturing location, please contact the Ennis HOTLine at (800) 972.1069.

Continuous forms allow any average composition your customers want. Special features allow you to personalize your customers' continuous forms. Ennis offers a wide variety of features that allow your customers to design continuous forms to fit their specific needs.

Carbons normally fasten in one margin to allow for easy separation of carbons and paper parts.

Personalize the heading area of the form with logos and company addresses.

Add numbering (crash or press) numbering for numerical control.

Crimping in the margins is the standard form of fastening. For more permanent fastening, line or spot gluing may be used.

Round corners are no charge.

Reverse areas highlight important information at no charge.

Any screened areas are no charge.

Screened phantoms add interest to body of form. (There is an upcharge on new orders only, please call for pricing.)

Standard 1/2" margins may be moved in or out or eliminated at no charge.

The diagram shows a continuous form layout with several key features:

- Top Left:** A shaded triangular area representing a carbon fastener.
- Top Center:** A heading area containing the text: "Your Customer's Logo", "Your Customer's Company Name", and "Your Customer's Address".
- Top Right:** A numerical control area with the number "12345".
- Left Margin:** A vertical strip containing the text "Your Company Imprint City, State, Zip".
- Table:** A table with four columns: "#", "Date", "Description", and "Amount". The "Description" column contains a graphic of a hand holding a pen.
- Bottom Center:** A rectangular area labeled "ORIGINAL".
- Right Margin:** A vertical strip with a series of dots representing crimping points.

Keep your company name in front of your customers by adding your dealer imprint in the margin.

Marginal words identify individuals parts and may be positioned anywhere on the form at no charge.

CONTINUOUS LETTERHEADS

Continuous Letterheads are produced as a continuous web with only perforations between each letterhead, not cut into individual sheets. Printed on a variety of laid and linen stock, continuous letterhead features Envisi-perf perforations on all four sides to give a clean edge all around the sheet. The clean edge gives the appearance of a single letterhead, while the continuous construction lets your customers generate their letters by computer. Available as custom continuous only.

Form Measurement Continuous letterhead is first measured, left to right, full width of the form, including the margins. Continuous letterhead requires $\frac{3}{16}$ " lock up with no printing at the top and bottom, at right angles to the margins. Shaded areas on the illustration show lock up areas.

Company logos, no charge, if furnished correct size.

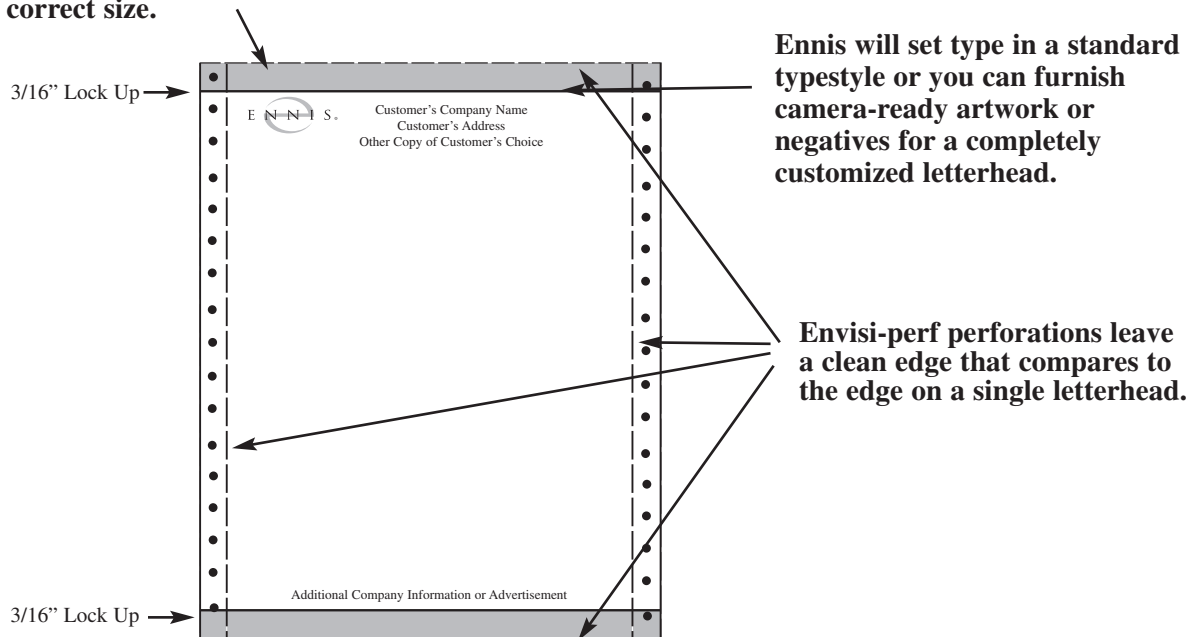

Ennis will set type in a standard typestyle or you can furnish camera-ready artwork or negatives for a completely customized letterhead.

Envisi-perf perforations leave a clean edge that compares to the edge on a single letterhead.

Available Features:

Number of Parts One

Paper Eight paper stocks to choose from including bond, rag content, Gilcrest Laid, Nekoosa Linen, and Neenah Classic Laid. Many of today's popular colors available in the laid and linen stocks. (Linen stocks can only be produced in 8 piece order quantity minimums.)

Ink Seventeen standard ink colors available at an upcharge. Match ink available at an upcharge. Can produce up to four colors of ink at some plants.

Composition Includes our setting in standard type and your camera-ready logo. You may furnish negative or camera-ready artwork, correct size, at no charge. Allowance is given for exact repeat orders.

Perforation $\frac{1}{2}$ " marginal perforations are standard. Marginal perforations, top perforations and bottom perforations are all Envisi-perf. Envisi-perf is a special perforation that allows the margins to be removed and the letterheads separated, leaving a clean edge instead of the serrated edge found on most continuous forms.

Punching None

Quantities 1,000 to 200,000. Larger quantities available, please call.

Manufacturing Locations To be connected to the nearest manufacturing location, please contact the Ennis HOTLine at (800) 972.1069.

Cut sheet singles are forms manufactured as individual sheets of paper. Available in a wide variety of sizes and paper stocks, cut sheet singles adapt to many purposes: scratch pads, advertising flyers, raffle tickets, order forms, letterheads and self-mailers.

Form Measurement

Cut sheet singles are run on a 17" sheeted press. Many sizes available from this press size. The width of a cut sheet is the sheet edge, which runs parallel to the 17" side. 1/4" lock up with no printing is required at right angles to the standard widths. Shaded areas on illustrations show 1/4" lock up areas.

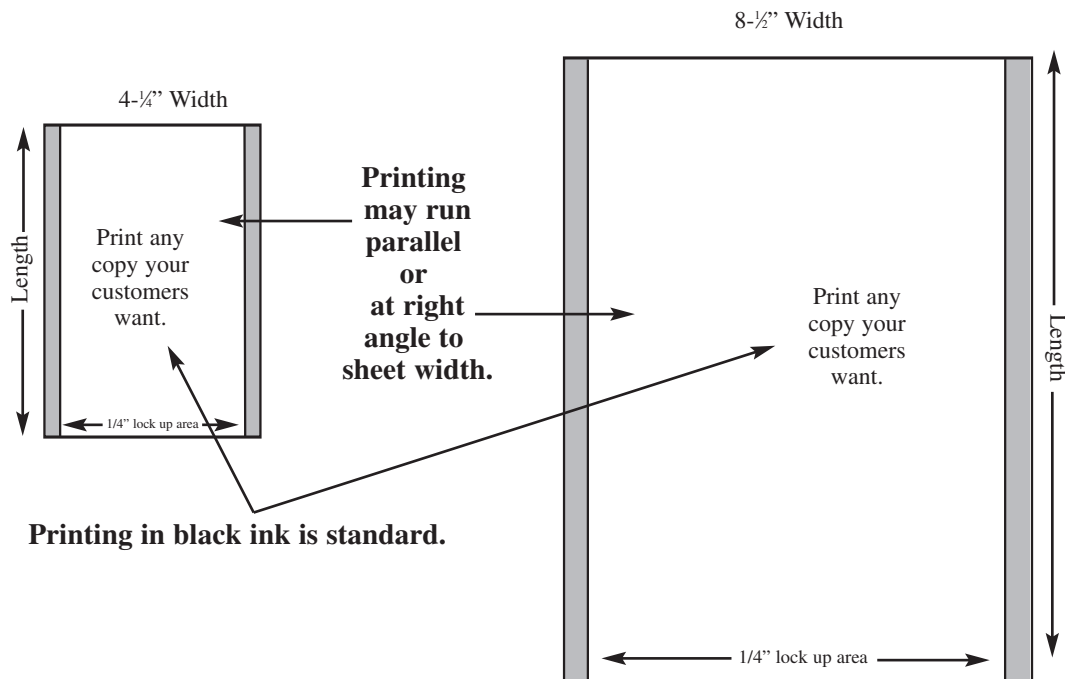

Available Features:

| | |
|--------------------------------|--|
| Basic Form Widths | 3 3/8", 4 1/4", 5 3/8", 8 1/2", 17" (Widths may be trimmed to intermediate sizes at an upcharge.) |
| Basic Form Lengths | 5 1/2", 7", 8 1/2", 11" (Lengths may be trimmed to intermediate sizes at no charge.) |
| Paper | White and colored 20 and 24-lb. white bond. Colored bond is available at an upcharge. Rag content, ledger and postal grade stocks available. |
| Ink | Printing in colored inks, available at an upcharge. Back printing and match inks available at an upcharge. 3 colors maximum. |
| Composition | Camera-ready artwork or negative is required. If camera-ready artwork or negative is not furnished, contact plant serving your area for pricing. |
| Numbering | Press numbering available at an upcharge. For more than one number per sheet, contact the plant serving your area for availability and pricing. |
| Perforation | Available at an upcharge. Perforations must run parallel to the 8 1/2" or 4 1/4" width, full width of the sheet (can have parallel or right angle perforations). |
| Punching | 1, 2 or 3 hole punching available at an upcharge. |
| Folding | Available at an upcharge. |
| Padding | Padding of cut sheet singles to a chipboard back is available at an upcharge. Sheets can be gum padded 25, 50 or 100 per pad on any side. |
| Quantities | 5,000 to 1,000,000. Larger quantities available, please call. |
| Manufacturing Locations | To be connected to the nearest manufacturing location, please contact the Ennis HOTLine at (800) 972.1069. |

Books are groups of single or multi-part forms bound together in one common binding stub. For multi-part books, pencil carbons are generally bound in the back of the book. Book construction provides both numerical control and portability.

Form Measurement Width of binding stub is measured first. Book length includes binding stub.

Types Of Books: Books are divided into four main types. Book types are based on construction of the book. Available as custom only.

1. Sales Books

Bound in wrap-a-round covers, 50 sets per book. Carbon interleaves from bottom of book. Original printed in black ink, duplicate in red ink. Check numbering 1-50 is standard. Four standard sizes available. Paper is manila with bond paper available at an upcharge. Quantities from 100 to 5,000 books. For larger quantities contact Customer Sales/Service.

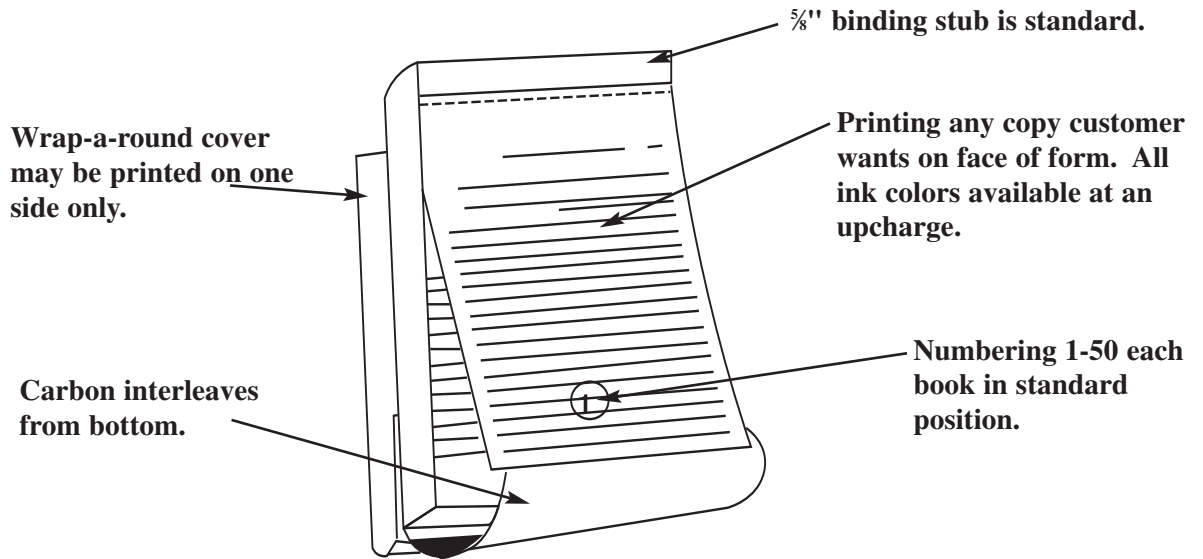

2. Folded Sales/Deposit Books

Bound in wrap-a-round covers, 50 sets per book. Duplicate sets are perforated at the fold. Duplicate is perforated at the binding stub. Carbon interleaves from the top. Original is printed in black ink. The duplicate is red ink. Check numbering 1-50 is standard. Two sizes available. Paper on folded sales books is manila. Paper on folded deposits books is bond. Quantities from 250 to 5,000 books. For larger quantities, contact Customer Sales/Service.

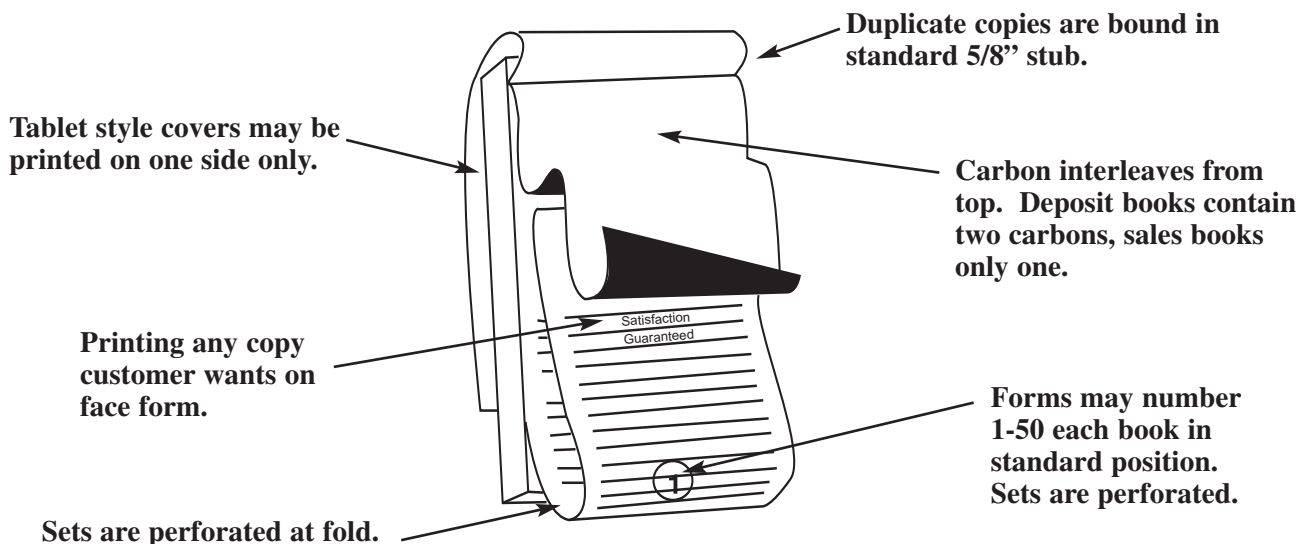

Types Of Books Continued:

3. Manifold Books Bound in tablet style covers, 50 sets per book. Carbons are perforated at the binding stub to insert between the form parts. A variety of papers include bonds, carbonless, manila and tissue sheets. Tissue parts are not perforated at the stub. 21 various standard sizes. Colored inks and two-color printing available at an upcharge. Punching is additional. Part to part changes and back printing available at an upcharge. Quantities from 125 to 5,000 books. For larger quantities, contact Customer Sales/Service. (See Ennis Instant Connection Brochure.)

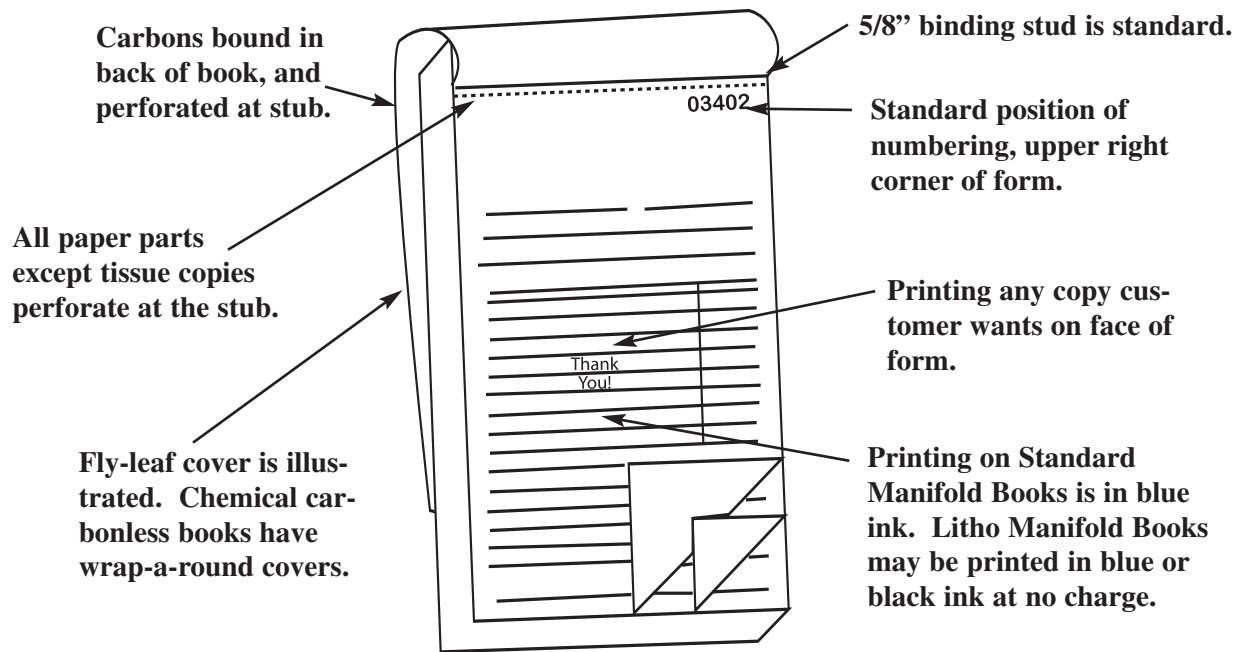

2. Padded Cut Sheets All Originals

Single forms bound to a chipboard back with gum padding. Standard padding is 50 or 100 sets per pad. Blue ink on front of 15-lb. white bond is standard. Padded all originals have no carbons in pad. Standard sizes are available. Quantities from 250 to 5,000 pads. For larger quantities, contact Customer Sales/Service.

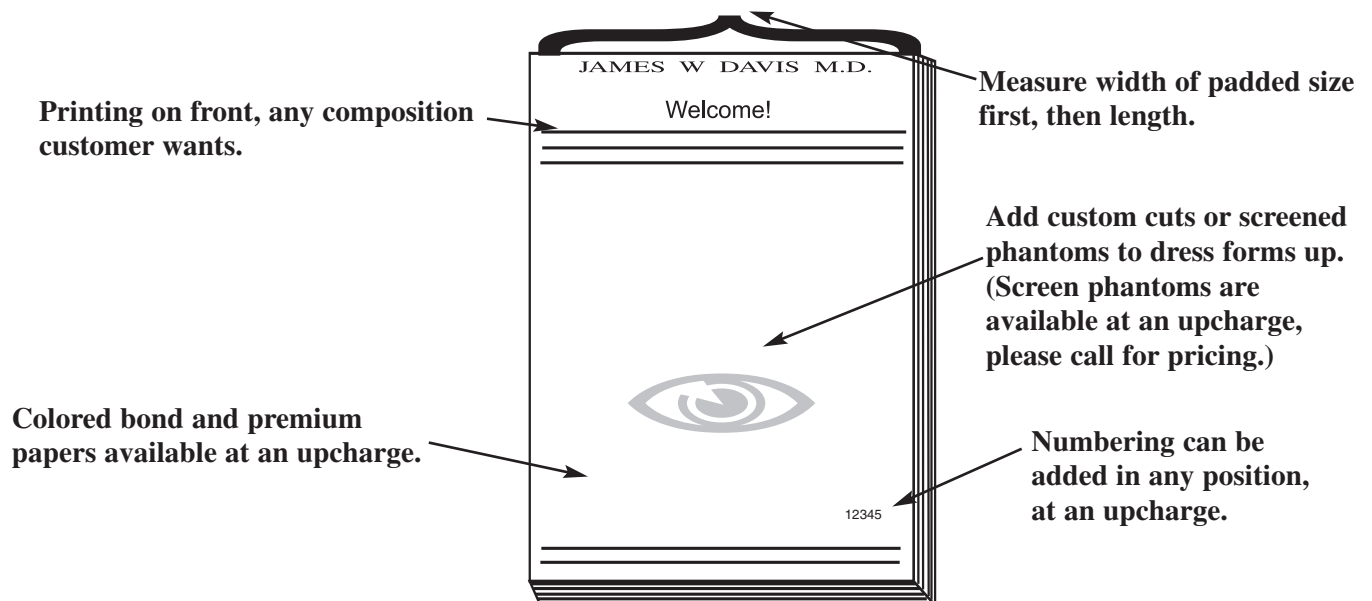

Manufacturing Locations

To be connected to the nearest manufacturing location, please contact the Ennis HOTLine at (800) 972.1069.

GUEST CHECKS

Guest checks are forms designed to serve as a record of food or drink orders in restaurants or bars. Guest checks also act as sales tickets and receipts.

Form Measurement Width of the guest check is given first. Guest check length should include binding stubs and receipt portion of form.

Types of Guest Checks Booked and Loose checks.

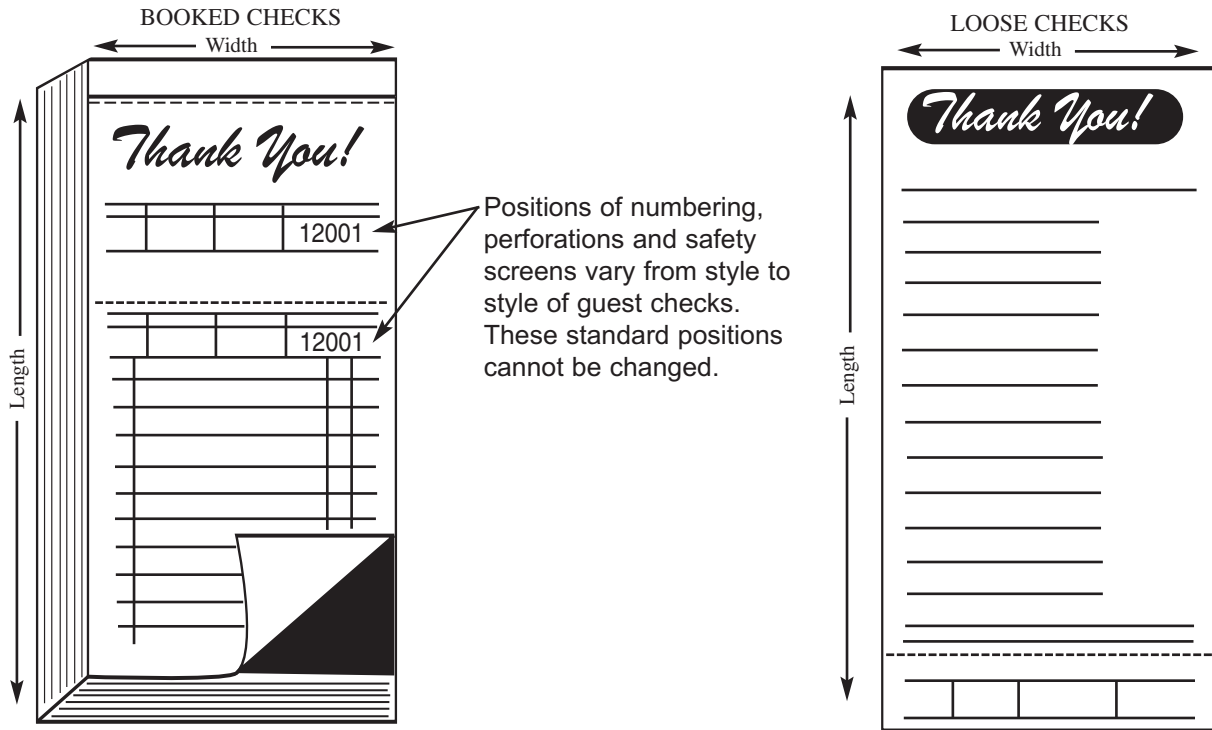

Available Features:

- Standard Sizes** Various basic sizes.
- Number of Parts** Single or duplicates.
- Paper** A variety of papers including manila, bond, board and carbonless papers.
- Carbon** Carbon interleaved from bottom of book or carbonized book papers.
- Ink** Blue ink with green safety screen or brown ink with buff safety screen.
- Composition** Any printing customer wants in base color of ink. Position of safety screen cannot be changed. Allowances given for use of standard body formats.
- Numbering** In standard positions only. Consecutive or book and check numbering.
- Perforation** Binding stub perforations or receipt perforations in standard positions.
- Punching** None
- Binding** Bound 50 or 100 checks per book. Booked forms are wire stitched to a chipboard backer.
- Quantities** Booked checks - 250 and up.
Loose checks - 10,000 and up.
For larger quantities, please call.

Manufacturing Locations To be connected to the nearest manufacturing location, please contact the Ennis HOTLine at (800) 972.1069.

GUEST CHECKS



Guest checks may be printed with any information your customers want in the base color of the form. Other features vary from one style check to another, but must remain in standard positions.

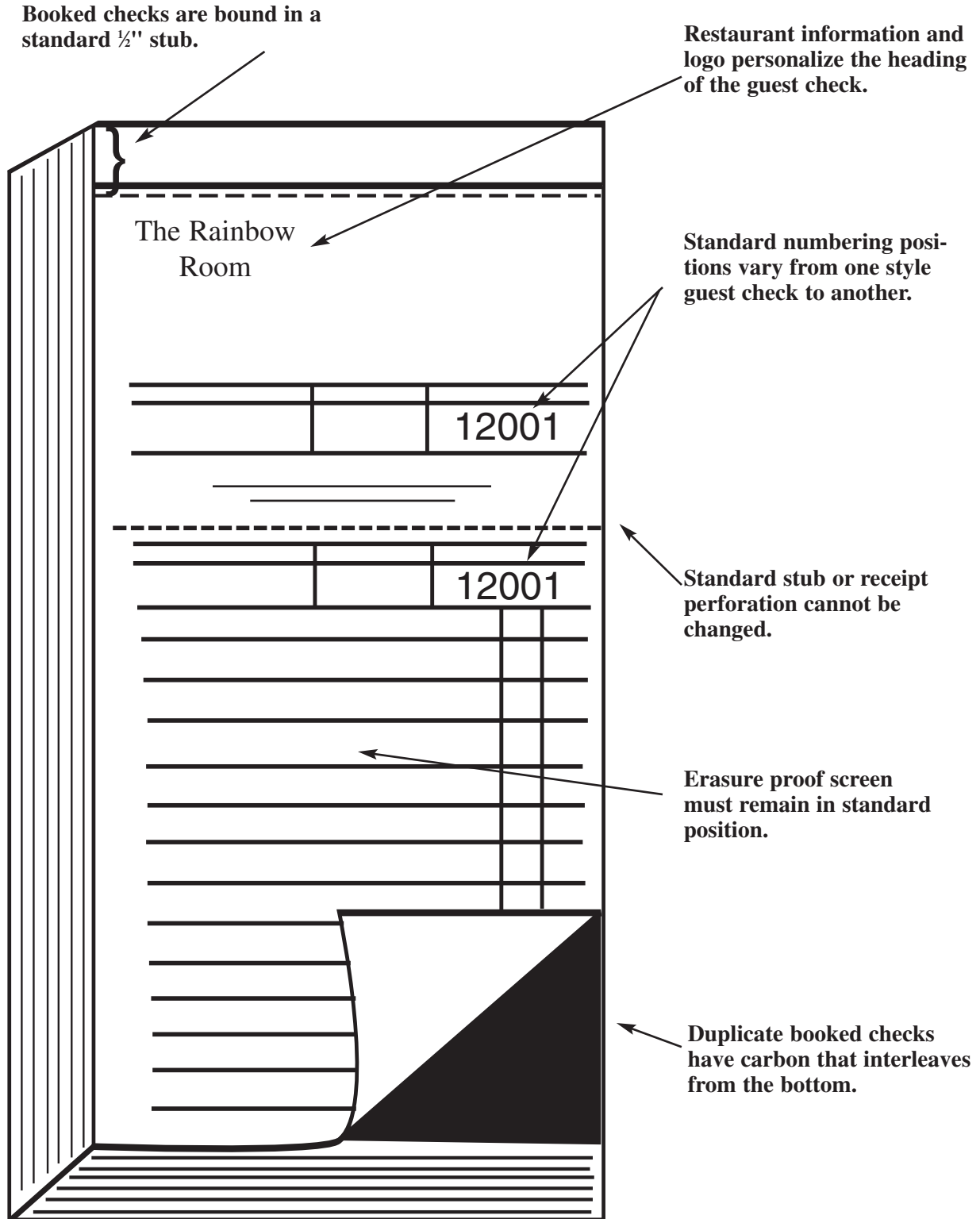

Styles of Guest Checks

Each style varies by size of features offered. Most styles are offered both as stock, on the shelf items, or printed with your customer's copy.

REGISTER FORMS

Register forms are multi-part forms in a continuous web, with no fastening features, to allow use of pencil carbons in register machines for copies. Register forms are also available in carbonless papers. The make and model of the register machine determines overall size and punching necessary on the forms.

Form Measurement Measure the width of the form first; length, second.

Types of Register Forms Pre-set body, Thrifti-line and Custom.

Pre-Set Body

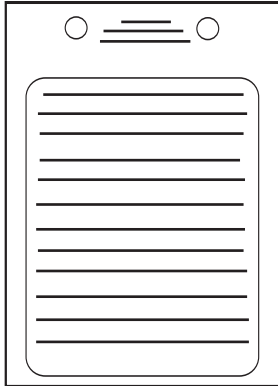

Customer's copy is printed in heading of form, only.

Pre-set body copy may not be changed. Ennis offers your customer a choice of several hundred pre-set body formats.

Thrifti-Line

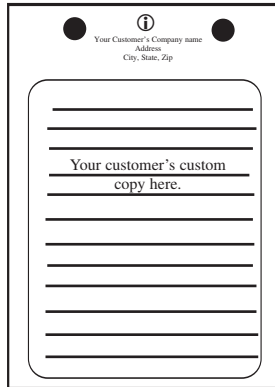

Entire form may be printed with customer's copy.

Thrifti-line forms are limited to standard sizes, standard papers and standard ink colors.

Custom

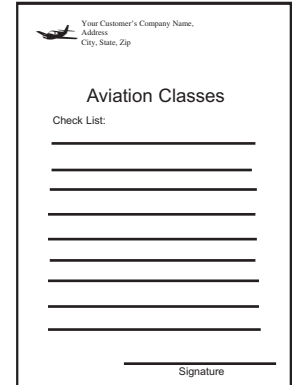

Custom forms are fully customized as to copy and construction of form.

Colored inks, ledger and tag stocks, additional perforations and back printing are available.

Available Features:

| | |
|---------------------------|--|
| Basic Form Widths | 4", 4 $\frac{1}{4}$ ", 4 $\frac{5}{16}$ ", 5 $\frac{1}{16}$ ", 5 $\frac{1}{2}$ ", 5 $\frac{3}{4}$ ", 8 $\frac{7}{16}$ ", 8 $\frac{1}{2}$ " |
| Basic Form Lengths | 3 $\frac{1}{4}$ ", 3 $\frac{1}{2}$ ", 3 $\frac{3}{8}$ ", 4 $\frac{1}{4}$ ", 5 $\frac{1}{2}$ ", 6", 6 $\frac{1}{2}$ ", 7", 7 $\frac{1}{8}$ ", 8 $\frac{1}{2}$ ", 11" |
| Number of Parts | 2 through 5 |
| Paper | 12, 15 or 20-lb. bonds. Carbonless papers. Ledger and tag stocks. |
| Carbon | None. Pencil carbons remain in the register machines as the forms pull through. Carbons may be rolls or sheets. |
| Ink | Black and blue inks are standard. Other colors and match inks available at an upcharge, custom only. Back printing available only on custom forms. |
| Composition | Pre-set body composition allows customer's copy only in heading of form. Thrifti-line and Custom allow customer's copy in heading and body form. Allowances are given for camera-ready art or negatives. |
| Numbering | One consecutive number in red ink on all parts. |
| Perforation | Between sets is standard. Extra horizontal on vertical perforations available only on custom forms. |
| Punching | Punching is determined by type of register machine. Round hole, slot hole, or linehole punching is available. Refold punching on copies is available to refold parts back into register machine. |
| Quantities | 2,500 and up. For larger quantities, please call. |

Manufacturing Locations

To be connected to the nearest manufacturing location, please contact the Ennis HOTLine at (800) 972.1069.

Stock forms that have a pre-printed body format with a blank heading area, which is crash imprinted with the customer's heading information. This type of personalization is more economical than a fully customized form.

Form Measurement Forms are measured width, first; length, second.

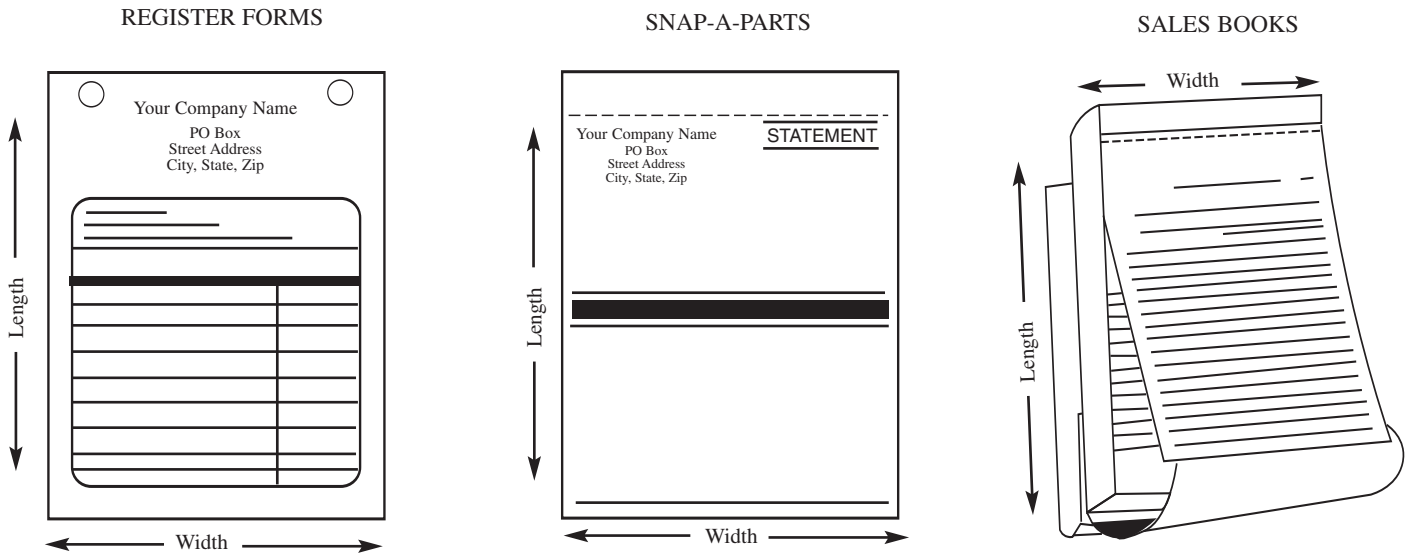

Available Features:

- Basic Form Sizes** Pre-printed body formats are available in a variety of the most popular sizes for each type of form.
- Types of Pre-Printed Body Formats** Automobile Forms, Business Forms, Contractor Forms, Envelopes, FAX Forms, Gift Certificates, Memos, Packaged Forms, Quotation Forms, Rental Forms, Repair Forms, Sales Forms, Shipping Forms and more.
- Number of Parts** Varies by form: Register Forms - 2, 3 and 4 parts.
Snap-A-Part Forms - 2 through 5 parts.
Books - 2 and 3 parts, wire-o bound and stitched.
- Paper** Multi-part forms are supplied either carbon interleaved or black-print carbonless.
- Ink** Imprint information is in black, red, blue or green ink on forms. Thermographed letterheads can be imprinted in one or two colors. Eight standard colors of ink are available.
- Composition** Forms are crash-imprinted in the heading area with 3, 4 or 5 lines of type available. Logos may be imprinted if camera-ready art is provided in the correct size, or you may choose from our large selection. Thermographed stationery offers 12 typestyles and a choice of eight heading formats.
- Numbering** Consecutive crash numbering is available on most imprinted forms. If forms are ordered without an imprint, and a specified number is required, pricing will be same as an imprinted form. Otherwise numbering cannot be specified.
- Punching** Punching varies from form to form. Only forms illustrated with punching in the Business Forms & Supplies Catalog have punching. Call for special punching requirements.
- Perforation** Only stub and receipt perforations as illustrated in catalog.
- Quantities** 250 and up. For larger quantities, please call.
- Manufacturing Locations** To be connected to the nearest manufacturing location, please contact the Ennis HOTLine at (800) 972.1069.

The Business Forms & Supplies (BF&S) Catalog illustrates more than 200 pre-printed body formats available for imprinting with your customers' heading information. These pre-printed formats include almost every type of form that is used in day-to-day business today. The snap-a-part illustrated below is marked to show features available to personalize the forms in this catalog. This catalog serves as a complete selling tool for Ennis distributors through Ennis' Cooperative Marketing Program. The Program allows customers to personalize the catalog with their logo and company information. For more information, contact the Ennis HOTLine at (800) 972.1069.

Imprint area varies from form to form. From 3 to 5 lines of type are available in the heading imprint area.

Custom logos may be added to the heading imprint area if camera-ready art, the correct size is furnished.

Carbonless snap-a-part forms may be booked in wrap-a-round covers at an upcharge.

Consecutive numbering is available on most imprinted orders. Beginning number can be specified on imprinted orders.

The pre-printed body format cannot be altered. (Check out "My Choice" creation if you need to alter the forms. See "My Choice" in the BF&S Catalog.)

Punching is available if illustrated in the catalog.

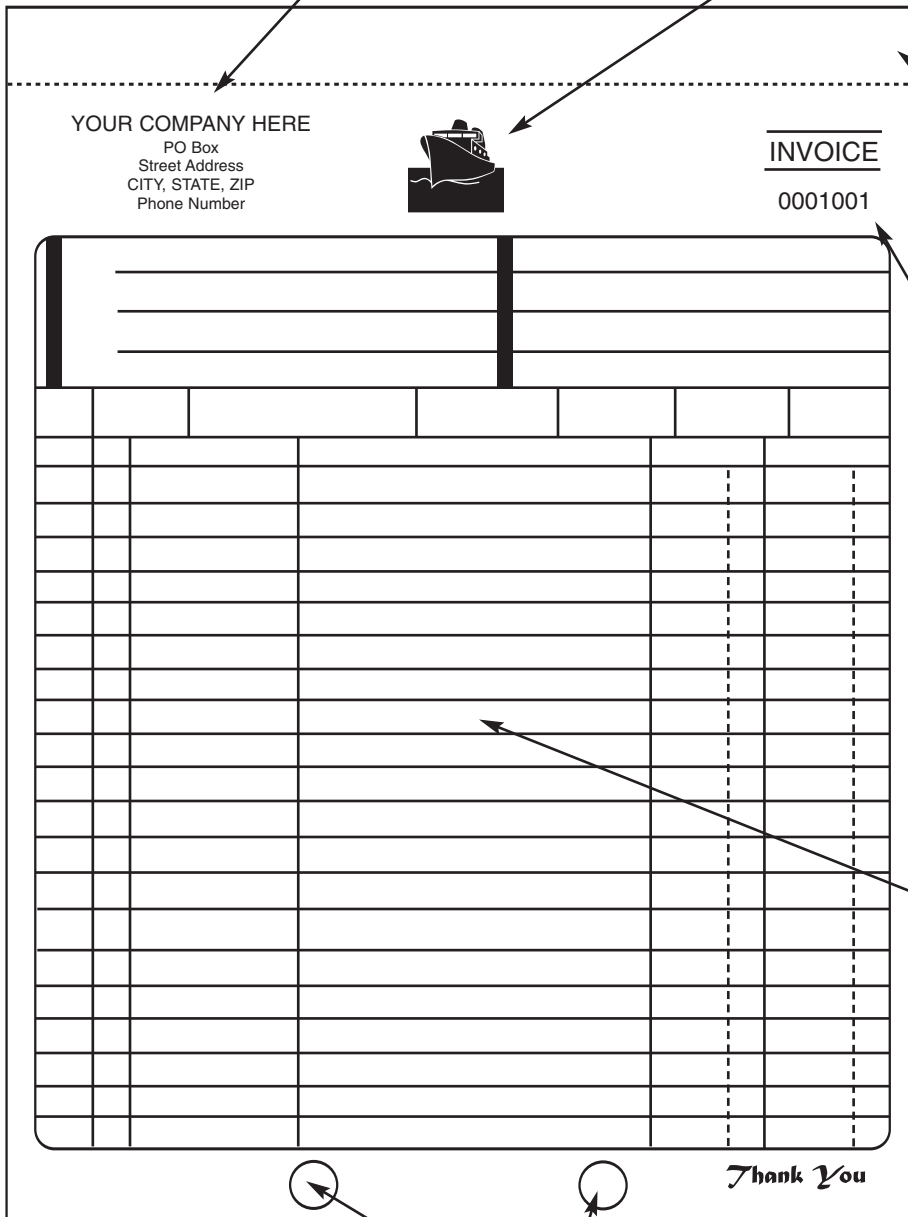

The diagram shows a business form with the following sections and features:

- Heading Area:** A dashed line separates the heading from the body. It contains the text "YOUR COMPANY HERE" followed by "PO Box", "Street Address", "CITY, STATE, ZIP", and "Phone Number". To the right is a logo of a ship and the word "INVOICE" above the number "0001001".
- Table:** A large table with multiple columns and rows, used for data entry.
- Footer:** The text "Thank You" is located at the bottom right of the form.
- Punching:** Two circles at the bottom of the form indicate where punching is available.

Software Compatible Checks & Forms are continuous or laser forms that have a pre-printed body format with a blank heading area, which is crash imprinted with the customer's heading information. This type continuous or laser form allows personalization of the form at less cost than a custom form.

Form Measurement Forms are first measured, left to right, full width of the form, including the margins. Length of form is measured second.

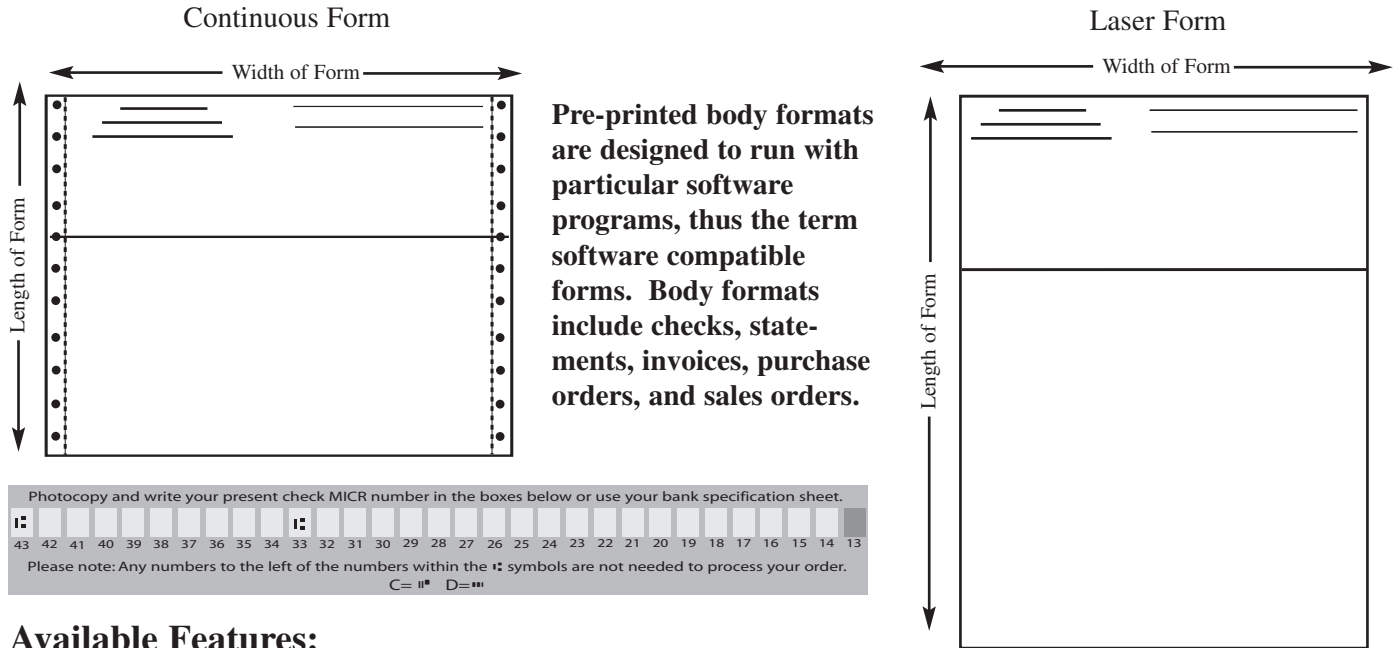

Available Features:

- Basic Form Widths** 7½", 8½", 9½", 10½", 11¼", 12", 14⅞" (Laser 8½" only)
- Basic Form Lengths** 3½", 3¾", 6½", 7", 8½", 11" (Laser 11" only)
- Number of Parts** 1-4 parts available in continuous forms; 1-3 parts available in checks.
- Paper** Continuous is black image on carbonless papers. Color sequence: white, canary, pink, goldenrod and white.
- Ink** Ink will be in black unless specified otherwise. The option of one PMS color is available for an upcharge.
- Composition** Five heading lines in a choice of 24 heading styles. On checks, two bank information lines, bank transit number, and static/consecutive MICR encoding are standard. (If your customers cannot locate a pre-printed body format that is compatible with their software, ask our plants about our ADVANCE SERIES.)
- Numbering** Numbering is in red ink or black on continuous at factory option. Numbering is no charge on checks and additional charge on forms orders. Laser forms and checks – black ink only.
- Perforation** Continuous forms perforate, left and right, at the margins. The only forms that have internal perforations are statements.
- Punching** None
- Construction** Forms are crimped in the left and right margins for fastening.
- Quantities** 250 and up. For larger quantities, please call.
- Manufacturing Locations** To be connected to the nearest manufacturing location, please contact the Ennis HOTLine at (800) 972.1069.

SOFTWARE COMPATIBLE CHECKS AND FORMS ENNISSM

The Software Compatible Forms (SCF) Catalog illustrates numerous pre-printed body formats available for imprinting with your customer's information. These pre-printed formats are compatible with over eight hundred software packages on the market today. One pre-printed form and one pre-printed check are illustrated below to show features available to personalize the forms. This catalog serves as a complete selling tool for Ennis distributors through Ennis' Cooperative Marketing Program. The Program allows customers to personalize the catalog with their logo and company information. For more information, contact the Ennis HOTLine at (800) 972.1069.

Specify the heading style of your choice for the imprinted heading information.

Camera-ready logos may be added at an upcharge.

The diagram shows a rectangular form with a dashed border. At the top left, there is a text field containing: "Your Company Name", "PO Box", "Street Address", and "City, State, Zip". To the right of this field is a silhouette of a horse. Further right, at the top, is the number "123456". A large, empty rectangular box occupies the center of the form. At the bottom center of this box, the text "Thank You!" is printed.

(Crash) numbering is additional on forms.

Additional lines of type in body of form are extra.

The diagram shows a check form with a dashed border. At the top right, the number "123456" is printed. Below this, there are several horizontal lines for writing. A horizontal dashed line separates the top section from the bottom section. In the bottom section, there is a text field on the left containing: "Your Company Name", "PO Box", "Street Address", and "City, State, Zip". To the right of this field, the text "Bank Anywhere, USA" and the number "123456" are printed. At the very bottom, there is a line of MICR encoding: "123456 : 99999999999999999999 : 99 999".

Arabic numbering in black is included in pricing on laser checks.

Bank information, bank transit number, and static/consecutive MICR encoding are imprinted in black ink. (The imprint can be in an ink color other than black if the rest of the check is printed in a standard PMS color. MICR and arabic numbers in black ink only.)

Specify the heading style of your choice for the imprinted heading information.

Pantographs are available in your choice of brown, burgundy, green blue, yellow, red or gray.

Check Security Features: The Mead® Defensa™ Line of Security Features can help you greatly reduce your risk of fraud. Mead® Defensa™ Security Papers meet or exceed ANSI Standards for MICR & OCR, and the paper is laser compatible. All software compatible checks are printed on Mead® Defensa™ Security Paper.

Features Include: Optically dead paper
Bleach and polar/non-polar solvent
Micro printing

Invisible fluorescent fibers
Padlock Icon

Tags are forms printed on stocks that are too heavy to be run on rotary form presses. Tag press capabilities allow manufacture of tags in many different shapes and sizes.

Form Measurement Tags are measured against a standard size chart, width first and then length.

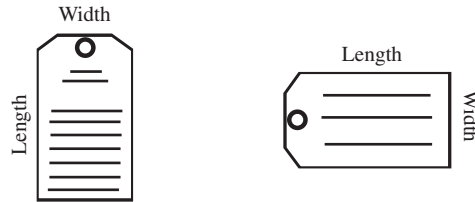

Styles of Tags Single, Manifold, Oversize and Continuous.

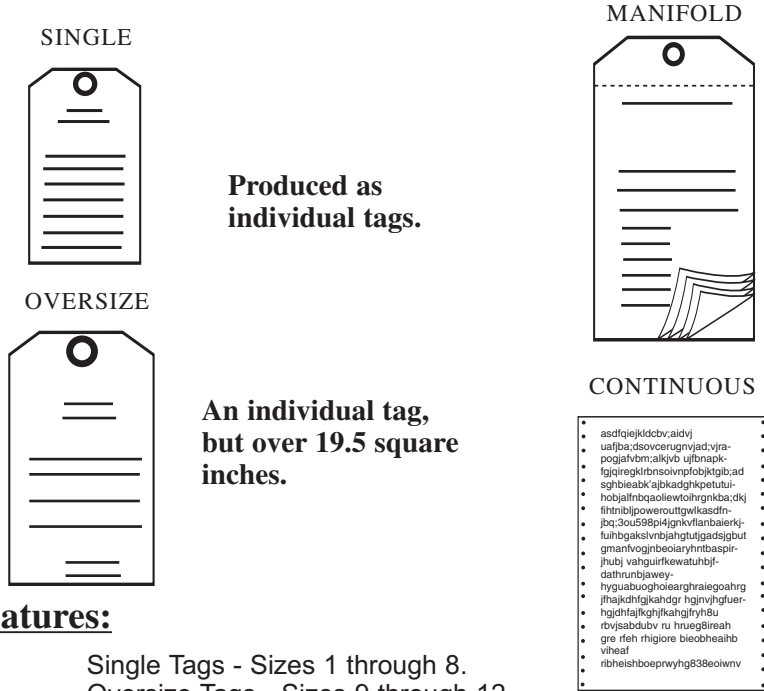

Produced as individual tags.

An individual tag, but over 19.5 square inches.

Multi-part tags, carbon interleaved or carbonless papers in 2 through 5 parts, including tag copy.

For use with computer printers.

Available Features:

- Basic Sizes** Single Tags - Sizes 1 through 8.
Oversize Tags - Sizes 9 through 12.
Manifold Tags - Sizes 1 through 12.
Continuous Tags - 10 square inches through 432 square inches.
- Number of Parts** 2 through 5 parts (Single tags, Oversize tags, and Continuous tags).
1 through 5 parts - Manifold tags.
- Paper** Numerous tag materials to choose from: uncoated paper, coated paper, water resistant, gloss coated stock material, heavy duty stock materials, carbonized paper and carbonless paper.
- Ink** 27 standard colors. Four-color, back printing (maximum of eight colors). Match Inks. Four-color process available.
- Composition** Medium composition, straight line type and rules. No extra charge for logos when camera-ready artwork is furnished.
- Numbering** Consecutive numbering from 1/32" up to 4" sizes. Numbering positions are almost unlimited. Ion Dep (consecutive barcode and large numbers) available at some facilities.
- Perforation** Horizontal or vertical perforations.
- Punching** Button dies, knife slots, slot punches and round hole punches. Custom punches or dies.
- Patching** One 9-16" round patch with 1/4" hole is standard. Additional patches, mylar strip patches and metal eyelets available.
- Stringing/Wiring** Tags can have strings, wires, metal fasteners attached and parcel hooks.
- Quantities** 1,000 and Up.

Manufacturing Locations To be connected to the nearest manufacturing location, please contact the Ennis HOTLine at (800) 972.1069.

Because of Ennis' wide variety of production capabilities, tags can be designed to fit business uses such as Time Cards, ID Cards, Rolodex Cards, Tickets and Price Tags. Use Ennis' special features to design the tag for your customer's specific business needs, including bar coding, consecutive numbering, perforations, punch and patch choices, and Wire and String options available. Tag materials include uncoated paper, coated paper, water resistant paper, gloss coated stock material, heavy duty stock material, specific paper for printer applications, carbonized paper and carbonless paper. The Tag Catalog illustrates these special features and the numerous tags available. This catalog serves as a complete selling tool for Ennis distributors through Ennis' Cooperative Marketing Program. The Program allows customers to personalize the catalog with their logo and company information. For more information, contact the Ennis HOTLine at (800) 972.1069.

Patches and punches are available in a variety of sizes.

Strings, wires or fasteners can be attached through the punch.

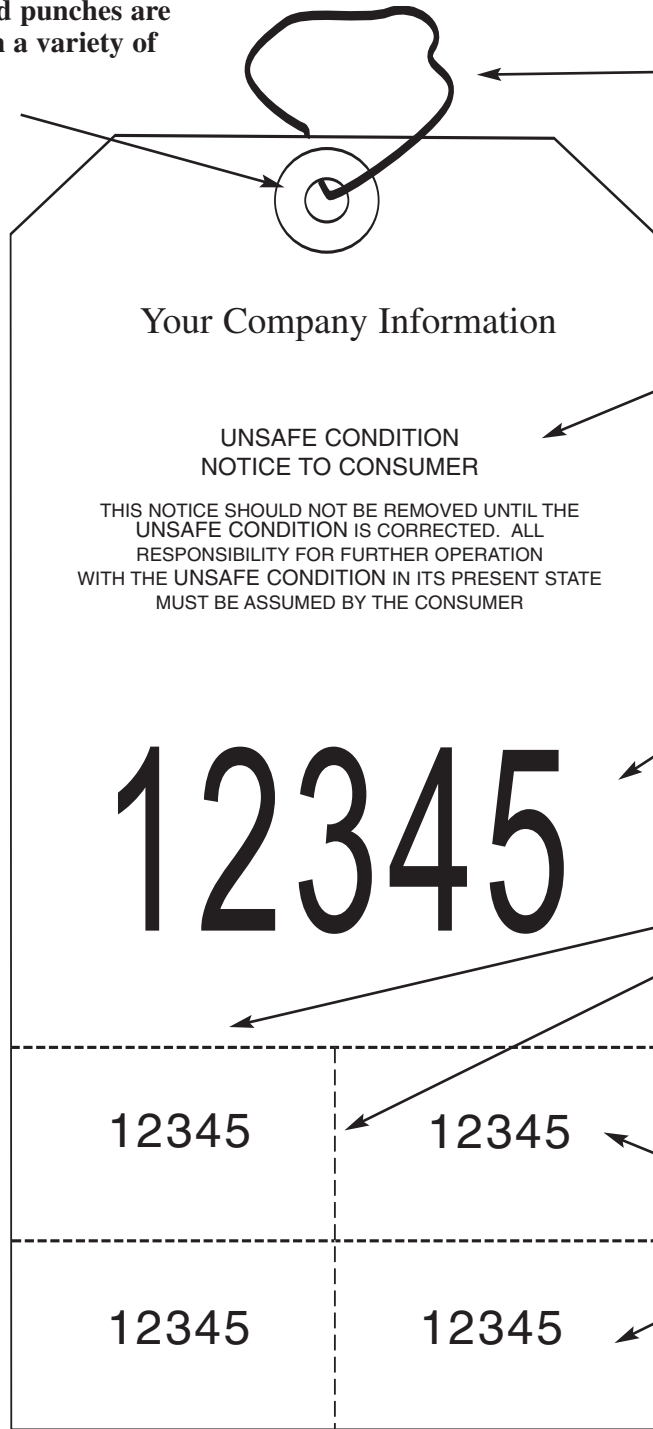

Standard size 9 is illustrated, 3 5/8 inch width x 7 1/2 inch length.

Labels are forms printed on an adhesive stock, which can be affixed to items for identification purposes. Labels take many shapes and sizes and serve a variety of business needs.

Form Measurement Labels are measured width, first; length, second.

Types of Labels Custom Pinfeed Labels, Custom Roll Labels and Custom Sheet Labels.

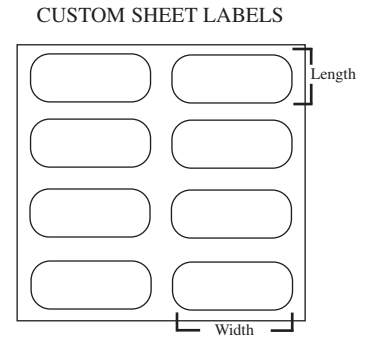
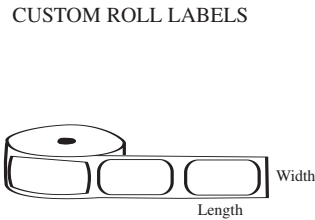
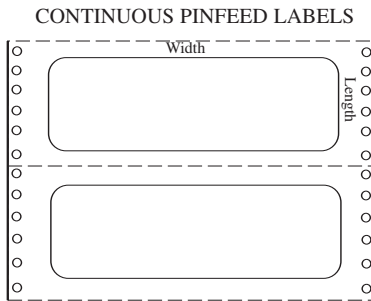

Available Features:

- Basic Sizes** Variety of sizes available.
- Number of Parts** 1
- Paper** 12 basic label stocks including permanent and removable stocks. Other stocks include matte and gloss finishes, vinyl and foil stocks.
- Ink** 27 basic colors. Printing on face in up to 8 colors of ink. Four-color process available.
- Composition** Typesetting in our standard typestyle is no charge. No charge for printing of customer supplied logos or camera-ready artwork
- Numbering** Available on property identification labels. Ion Dep (consecutive bar coding and large numbers) available at some facilities.
- Perforation** Horizontal or vertical perforations available.
- Punching** Available
- Types of Dies** Knife Cut Dies, Round Corner Rectangle Dies, Oval Dies, Circle Dies, Continuous Pinfeed Dies, Bend and Peel Labels. Also custom Dies available.

KNIFE CUT DIES
(Available in 28 standard lengths.)

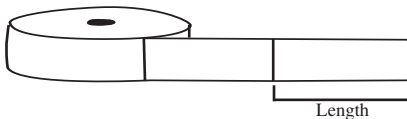

*CIRCLE DIES

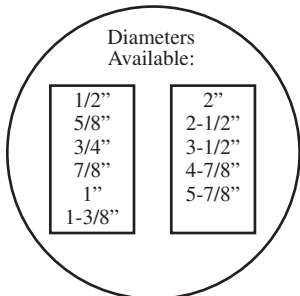

ROUND CORNER RECTANGLE (RCR) DIES
(Available in 50 standard lengths.)

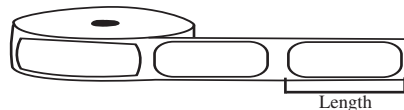

CONTINUOUS PINFEED DIES*
(Available in 36 standard lengths.)

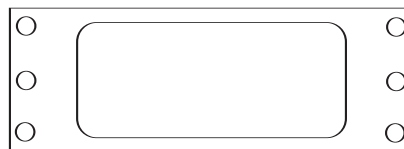

*Continuous Labels are available 1,2 and 3 across

BEND and PEEL LABELS
(Available in 23 standard lengths.)

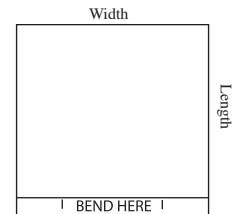

*OVAL DIES

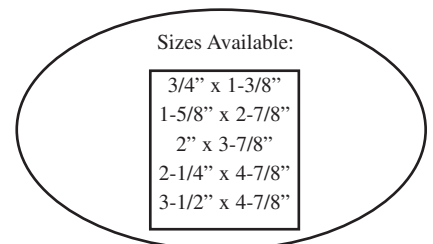

Quantities 1,000 and Up.

Manufacturing Locations To be connected to the nearest manufacturing location, please contact the Ennis HOTLine at (800) 972.1069.

* There are more sizes available with circle and oval dies.

Labels continue to hold the fastest growing segment of the business forms industry. Like tags, the variety of stocks available make labels suitable for use in many business situations.

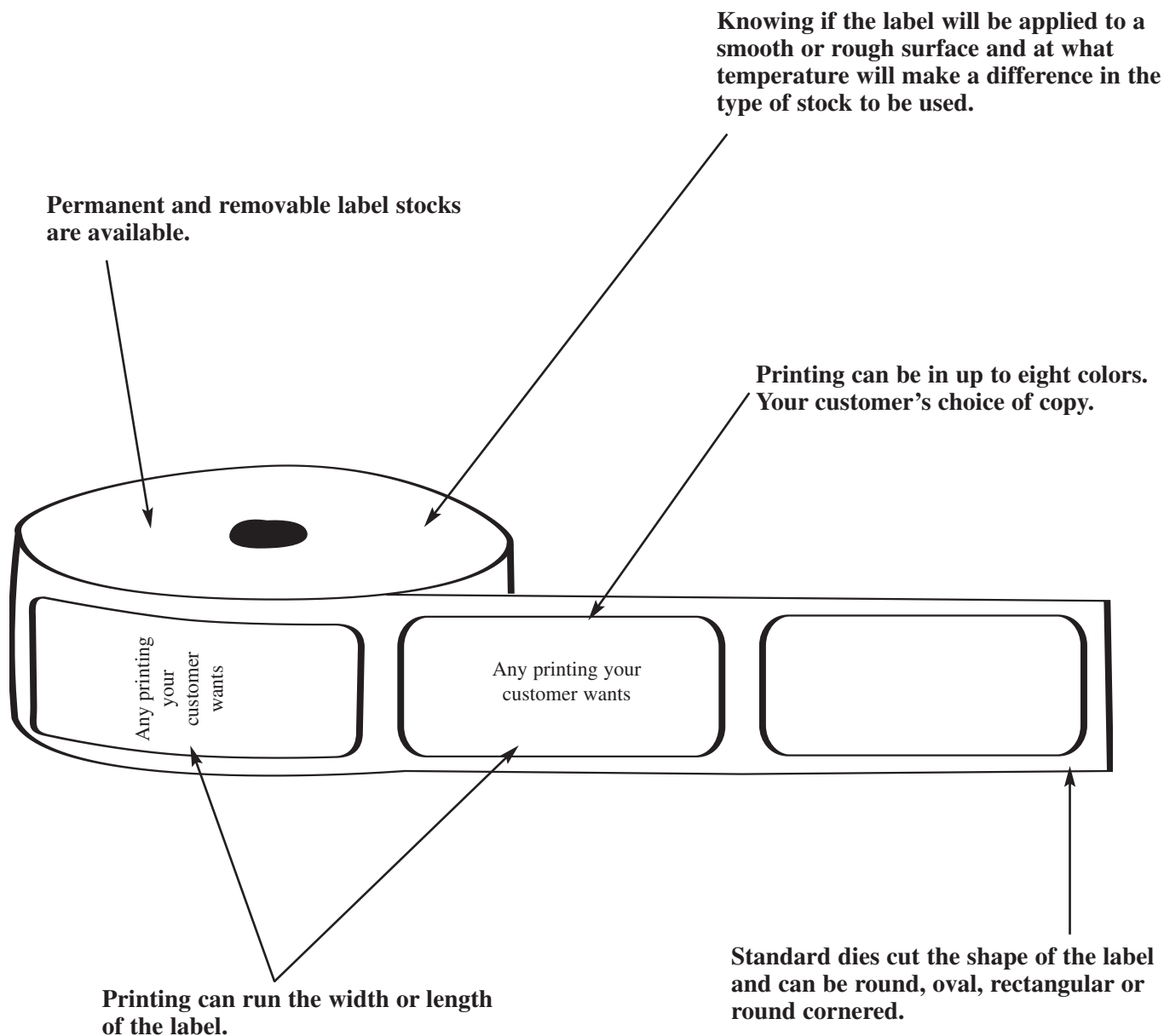

The Express™ Label Line:

When you need a label fast, Ennis has The Express™ Label Line available. Simply choose from six ink colors, 11 label stocks, available in a variety of typestyles from 500 to 10,000 quantity. The Express™ Label line catalog features the labels available with this line. This catalog serves as a complete selling tool for Ennis distributors through Ennis' Cooperative Marketing Program. The Program allows customers to personalize the catalog with their logo and company information. For more information, contact the Ennis HOTLine at (800) 972.1069.

“Did You Know” Ennis can do Integrated Labels too? For more information, call the Ennis HOTLine at (800) 972.1069.

SCREEN PRINTED PRODUCTS

Screen Printing is a process also called silk screening, where ink is transferred through a porous screen, such as nylon, onto the surface to be decorated. An emulsion or stencil is used to block out the negative or non-printing areas of the screen. A squeegee forces ink through the open areas of the screen and onto the paper, plastic, cardboard, wood, fabric, glass or other material.

Whether it's printing Business Card Magnets, Rotary File Cards, Custom Magnets or Bumper Stickers or Decals, the Advertising Specialty Division in Wolfe City, Texas has the screen-printed product your customers need. The Advertising Specialty Catalog illustrates some of the best selling screen-printed products on the market. This catalog serves as a complete selling tool for Ennis distributors through Ennis' Cooperative Marketing Program. The Program allows customers to personalize the catalog with their logo and company information. For more information, contact the Ennis HOTLine at (800) 972.1069.

Bumper Stickers

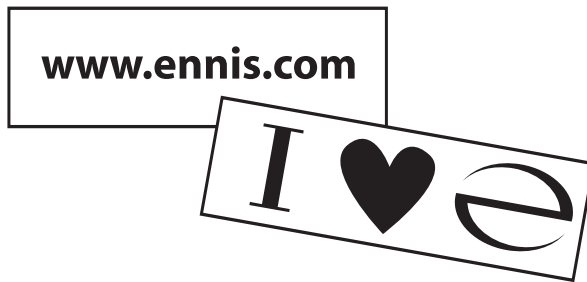

Custom Magnets



Membership Cards



Labels



Manufacturing Locations

To be connected to the nearest manufacturing location, please contact the Ennis HOTLine at (800) 972.1069.

Advertising Specialties include a wide variety of items that can be printed with your customers' information and used to advertise and promote their business. Literally hundreds of thousands of items can be printed with your customers' copy. Many are included in the Advertising Specialties Catalog. Whether it's printed balloons, key chains, BIC® pens, or golf accessories your customers need, Ennis Advertising Concepts Division in Wolfe City, TX can provide you with easy-to-sell printed advertising specialty items. These printed items expand the products and services you offer your customers and keep them coming back to you for all their printing needs. The Advertising Specialty Catalog illustrates the best selling advertising specialty products on the market. This catalog serves as a complete selling tool for Ennis distributors through Ennis' Cooperative Marketing Program. The Program allows customers to personalize the catalog with their logo and company information. For more information, contact the Ennis HOTLine at (800) 972.1069.

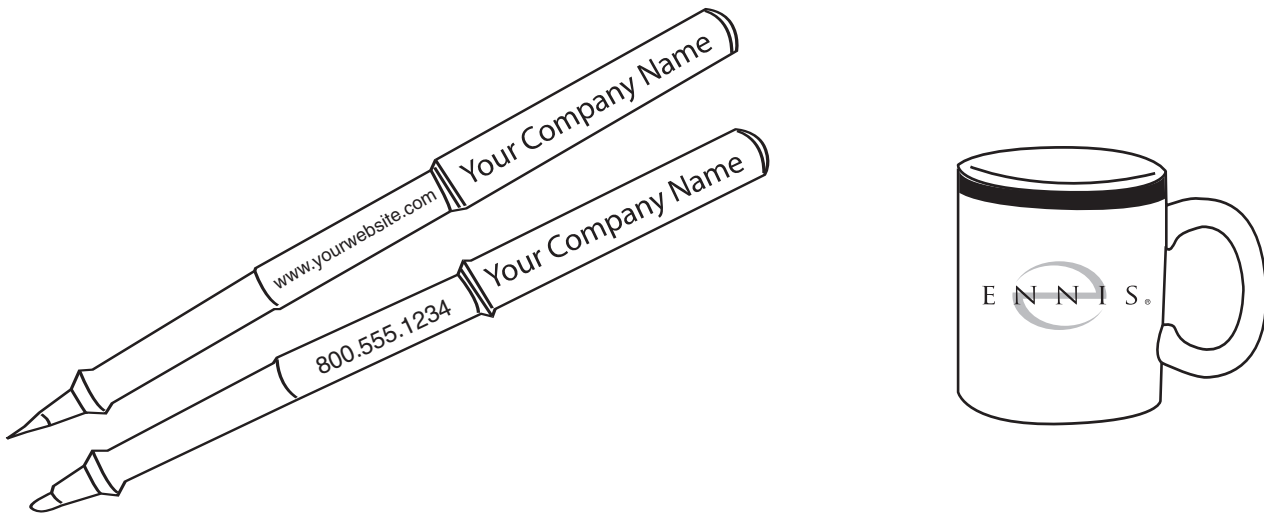

Advertising Specialties help customers remember a company's name. Encourage your customers to buy them printed with their company information and enjoy the increased profits you'll see from these additional sales.

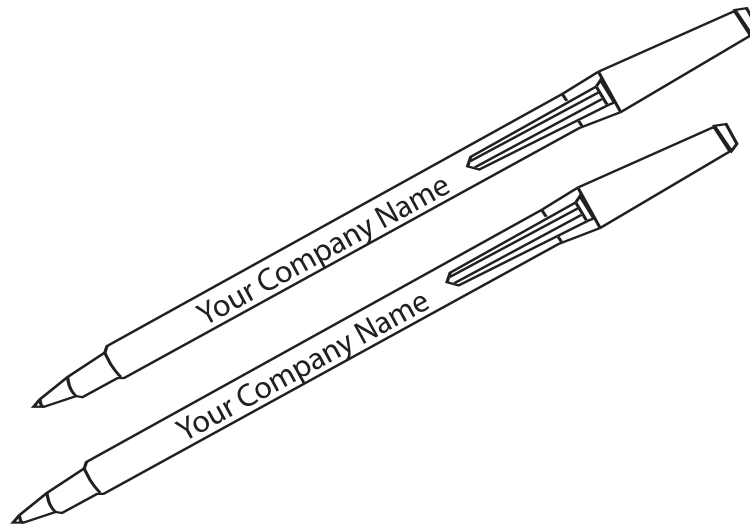

Manufacturing Locations

To be connected to the nearest manufacturing location, please contact the Ennis HOTLine at (800) 972.1069.

AWARDS & RIBBONS

The Star Award Ribbon Line includes a broad offering of award ribbons, armbands, badge ribbons, plastic badges, banners, certificates, custom buttons, custom award ribbons, custom rosettes, neck ribbons, pennants, recognition certificates, beauty sashes, tiaras and more. Each ribbon is handcrafted with the highest quality of satin. The Award and Ribbon Catalog illustrates these awards and ribbons. This catalog serves as a complete selling tool for Ennis distributors through Ennis' Cooperative Marketing Program. The Program allows customers to personalize the catalog with their logo and company information. For more information, contact the Ennis HOTLine at (800) 972.1069.

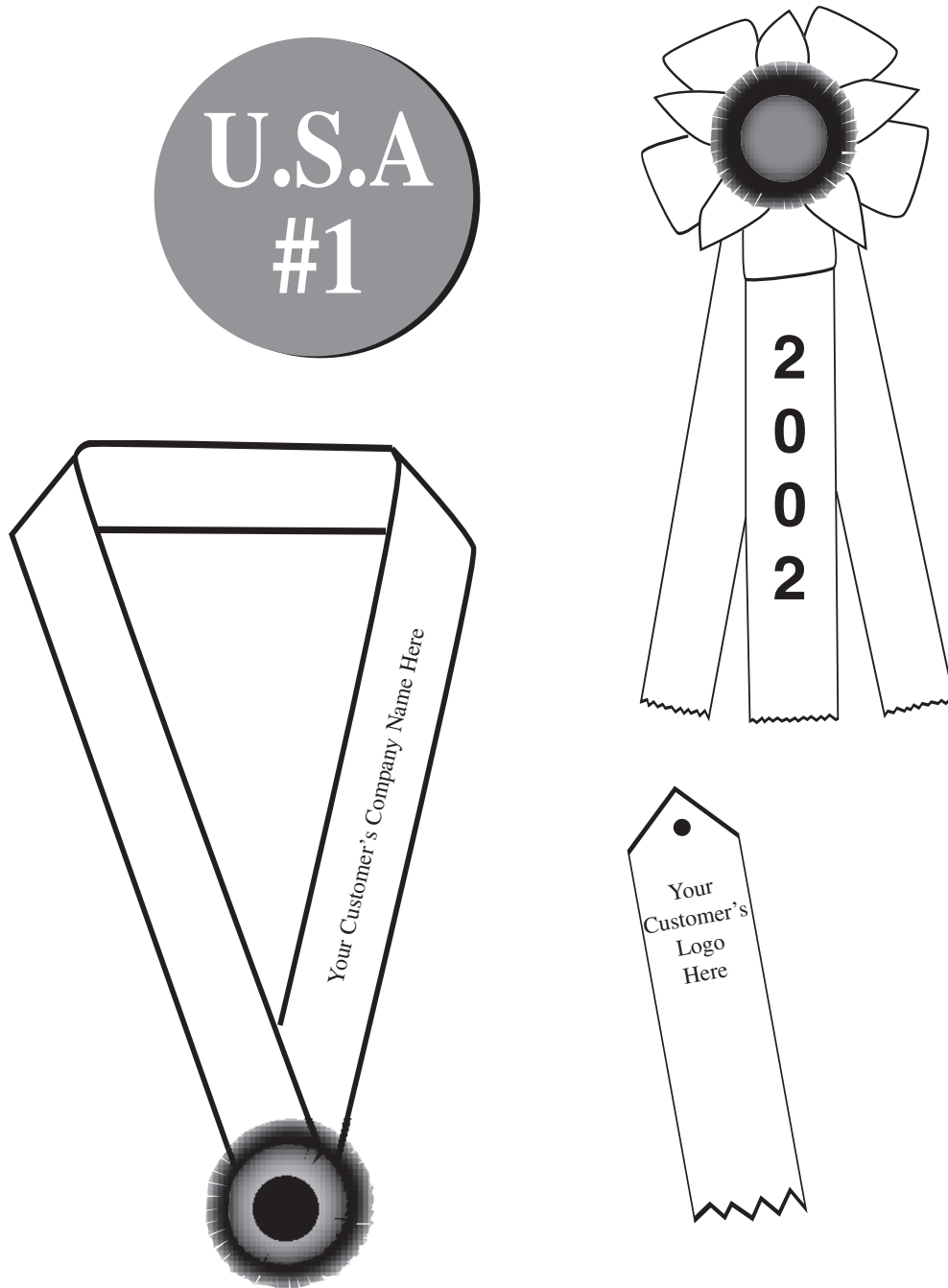

Manufacturing Locations

To be connected to the nearest manufacturing location, please contact the Ennis HOTLine at (800) 972.1069.

PRESENTATION PRODUCTS

(The Admore® Line)



The Admore® Line of Ennis manufactures a wide array of standard presentation folders and products that can be customized to fit the customer's needs.

Form Measurement Presentation folders are measured from left to right, full width of the folder. The length of the folder is measured second.

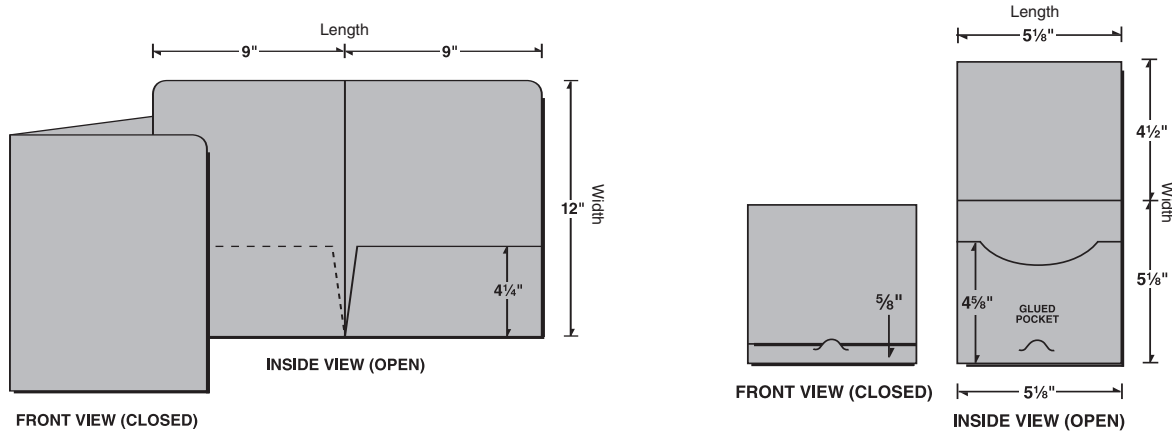

• Folder style 08-01

• CD holder style 26-03

Available Features:

- Basic Folder Sizes** The basic folder size measures 9" x 12" when closed with two 4 1/4" pockets. Business card slots, brochure slits and other pocket options are available. Other folder designs include reinforced edges, three panels, expansion pockets, capacities and legal size.
- Paper** Standard stocks include: Retreeve, Felt, Smooth Naturals, C1S Kromekote, White Marble Crush, Tweedweave, Hopsack, Vertical or Linen. Custom stocks are available on request.
- Ink** Four-color process, PMS colors and custom ink matches.
- Composition/Proof** Camera-ready art, films and Mac or PC files are accepted. Blueline and Color Proofing Systems.
- Embossing** Single level, multi-level and complex structured embossing is available.
- Foil Stamping** Metallic, non-metallic, special effect and custom foils are available.
- Spot and Flood UV Coating** A high-gloss finish applied to the sheet like a protective varnish. Exposure to ultraviolet light secures the finish to a brilliant shine.
- Varnish/Aqueous** Available in gloss or matte finish. A clear finish that seals the ink, offering protection against smearing and scuffing.
- Finishing Services** Collating and insertion, disk replication, hand assembly, velcro and handle attachment, ring mechanisms, spine attachments and fulfillment services available.
- Other Presentation Products** Software, CD and Video Packaging/Mailers, Totes and Boxes, Portfolios, Binders, Inserts, Mylar Tabs, Report and Certificates, Envelopes, Hotel Key & Gift Card Holders, CD Business Card Holders, Large and Small Presentation Folders, and Document Folders.
- Quantities** As low as 50 to larger quantities available.
- Manufacturing Locations** To be connected to the nearest manufacturing location, please contact the Ennis HOTLine at (800) 972.1069.

CUSTOM PRINTED Post-it® Notes (Large Quantity)

Post-it® Notes are padded single sheets with a removable adhesive edge on the back of each sheet that allows the sheets to be attached to and removed from another item. Post-it® Notes leave no residue on and causes no damage to the item to which they are attached.

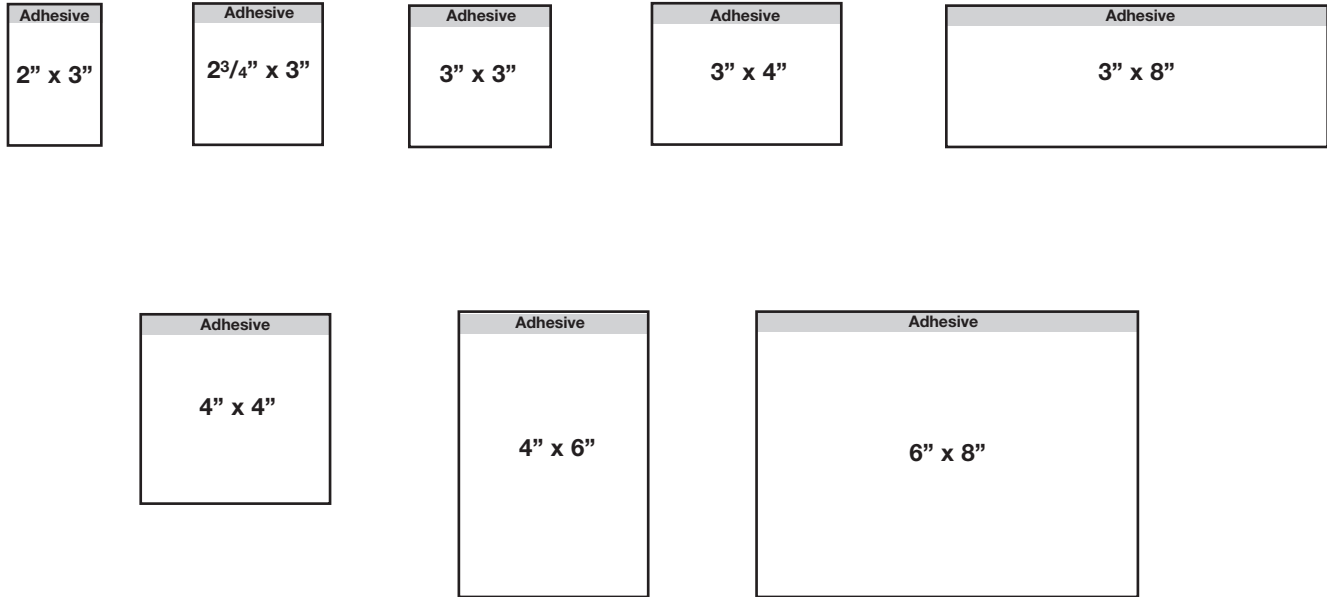

Available Features:

- Basic Sizes** 2"x3", 2³/₄"x3", 3"x3", 3"x4", 3"x5", 3"x8", 4"x4", 4"x6", 6"x8"
- Padding** 50 per pad is standard. Other sheet counts available, please call.
- Paper Colors** Blue, cream, green, light gray, neon pink, white and yellow. Also available at a 15% upcharge - neon yellow, neon orange, neon lime, neon melon, neon pink, ultra spruce, ultra green and ultra grape.
- Ink** Black, blue, brown, burgundy, green, teal, purple and red. Up to four-color printing available.
- Composition** Furnish camera-ready copy or we can set copy at a normal charge. Camera-ready must be black and white with no pre-screened art.
- Packaging** Boxed, shrink-wrapping available at an additional charge.
- Quantities** 500 pads or more.
- Manufacturing Locations** To be connected to the nearest manufacturing location, please contact the Ennis HOTLine at (800) 972.1069.

CUSTOM PRINTED Post-it® Notes (The Note-able Line™)



Post-it® Notes are padded single sheets with a removable adhesive edge on the back of each sheet that allows the sheets to be attached to and removed from another item. Post-it® Notes leave no residue on and cause no damage to the item to which they are attached. The Note-able Line™ Brochure illustrates these low quantity Post-it® Notes. This brochure serves as a complete selling tool for Ennis distributors through Ennis' Cooperative Marketing Program. The Program allows customers to personalize the brochure with their logo and company information. For more information, contact the Ennis HOTLine at (800) 972.1069.

Form Construction

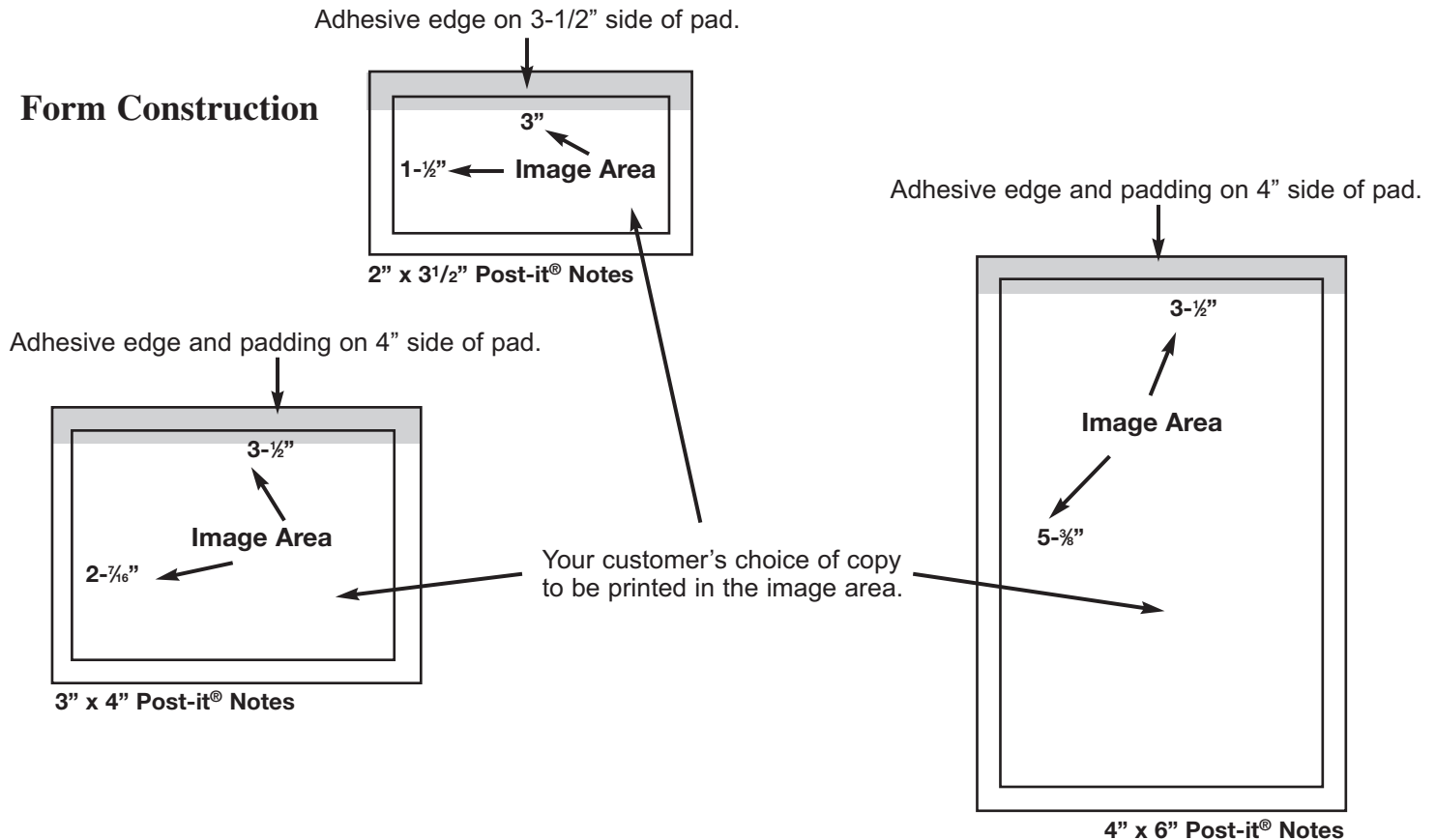

Available Features:

- Basic Sizes** 2"x 3 1/2", 3"x4" or 4"x6" overall sizes.
- Padding** 50 per pad is standard.
- Paper Colors** Blue, light gray, neon pink, white, and yellow.
- Ink** Black, PMS blue 300, PMS green 347, or PMS red 185 are standard colors.
- Composition** Five lines of copy in standard typefaces and sizes, are included in the basic pricing. There are many typefaces and type sizes to choose from. You may also furnish your own camera-ready copy. Camera-ready must be black and white, with no pre-screened art.
- Packaging** Boxed
- Quantities** Up to 500 pads.
- Manufacturing Locations** To be connected to the nearest manufacturing location, please contact the Ennis HOTLine at (800) 972.1069.



COMMERCIAL PRINTED PRODUCTS

Cutting edge technology has made it possible for Ennis to offer custom commercial printing at prices never before available.

From cut-sheet business cards to full color brochures, Ennis can make your printed product stand out from the competition. We provide exceptional four-color process printing with a full range of extraordinary services. Simply provide us with your negatives or electronic file and receive your high quality printed products promptly. Ennis delivers outstanding commercial printed products every time.

Products available:

- Sell Sheets/Flyers
- Rack Cards/Folders
- Postcards
- Business Cards
- Letterhead
- Greeting Cards
- Catalogs
- Brochures
- Booklets
- Posters
- Folders

Services:

- Color separations
- Typesetting
- Proofing
- Design work
- Electronic file transfer

Finishing Options:

- Folding
- Scoring
- Drilling
- Perfing
- Gloss varnish
- UV Coating
- Aqueous

Electronic File Specifications:

Mac or PC platforms accepted

Receivable Programs :

Quark Xpress
Pagemaker
Freehand
Corel Draw
Adobe Illustrator
Adobe Photoshop
Adobe Acrobat

Accepted Formats:

PDF
EPS
TIF
JPG
(Please call if you have other formats,
many can be converted.)

Financial Forms include a wide variety of items that can be imprinted with a bank customer's information. These forms are regularly MICR encoded and are used internally by banks and other financial institutions. Distributors can select from a large number of standard formats in either single-part or multi-part unit sets or create a customized form to meet their customer's specific requirements.

Form Measurement ANSI standards for MICR encoded interbank forms have been set between 2 $\frac{3}{4}$ " X 6" and 3 $\frac{5}{8}$ " X 8 $\frac{3}{4}$ ". Larger or smaller sizes are available for internal MICR forms. Copy other than encoding printed in magnetic (MICR) ink is restricted to the area above a horizontal line 5/8" from the bottom edge of the form.

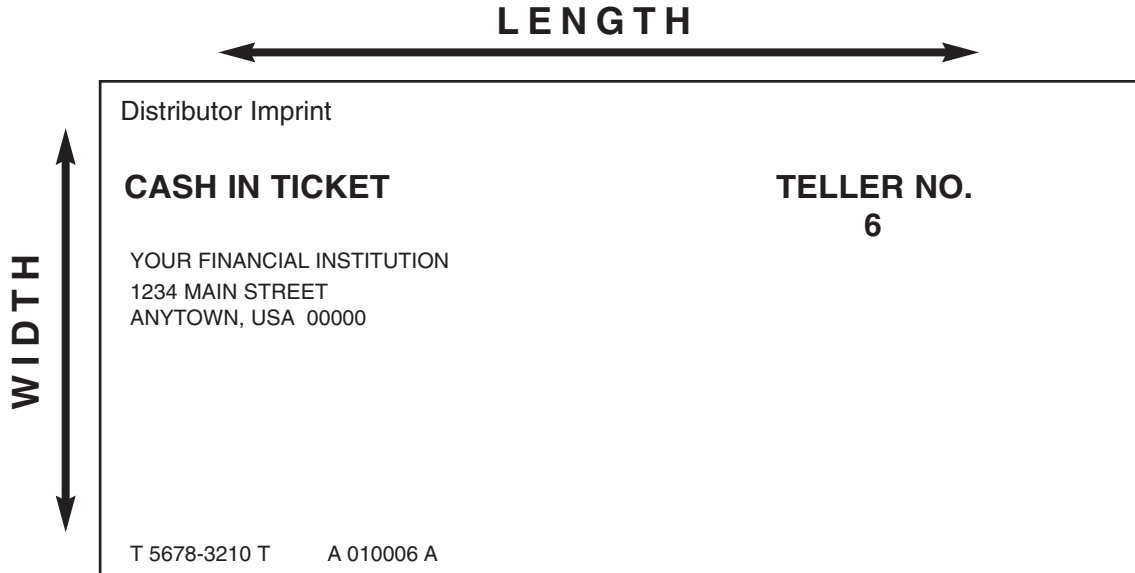

Available Features:

- Basic Form Widths** 2 $\frac{3}{4}$ ", 2 $\frac{5}{8}$ ", 3", 3 $\frac{1}{4}$ ", 3 $\frac{3}{8}$ ", 3 $\frac{1}{2}$ ", 3 $\frac{5}{8}$ ", 3 $\frac{3}{4}$ ", 4" and 4 $\frac{1}{4}$ ". (These are common sizes for internal MICR documents, but forms are not restricted to these exact sizes.)
- Basic Form Lengths** 5 $\frac{1}{2}$ ", 6", 7", 7 $\frac{1}{2}$ ", 8", 8 $\frac{1}{2}$ ", 8 $\frac{3}{4}$ " and 9". (These are common sizes for financial documents, but forms are not restricted to these exact sizes.)
- Paper** White and colored 15#, 20#, 22# and 24# bond plus White 28#, 32# and 36# ledger and 100# tag stocks available. Carbonless (self-contained) papers available include White, Pink, Blue, Green or Canary 17# and 22#. The 22# and 24# bond stocks are MOCR bond, which is suitable for MICR encoding, imaging, OCR and laser printed forms. Safety papers and security papers are also available.
- Ink** Black and MICR are free. Colored inks are available at an upcharge. Back printing also available in all colors.
- Composition** Clean sample, camera-ready copy or IBM compatible (.eps file preferred) electronic copy requested for new orders.
- Numbering** Regular consecutive, Book & Page, Hold & Repeat, Modulus and other special numbering in MICR and/or Arabic is available. Please call for capabilities and pricing for any form requiring special numbering.
- Perforations** Vertical and Horizontal perforations available. Please call for capabilities and pricing for forms requiring special perforations.
- Punching** Thumb notch and 1, 2 or 3 hole punching available. Please call for capabilities and pricing for forms requiring additional or special hole punching.
- Padding** Padding of single-part forms to a chipboard back is available. Pads of 25, 50 and 100 are commonly padded at the left, right or top of the form.
- Quantities** 200 to 30,000,000
- Manufacturing Locations** Bridgewater, VA • Golden, CO • Nevada, IA. Please contact the Ennis HOTLine at (800) 972.1069 to be connected to the facility nearest you.

OFFICIAL CHECKS

Financial Forms includes the SECURESTAR® line of Official Checks. It comprises a complete selection ranging from Cashier's Checks to Certificates of Deposit, and every design is layered with fraud-fighting features.

The SECURESTAR® features make it practical and affordable to protect every at-risk document issued by financial institutions. All SECURESTAR® documents are protected with the standard features shown on this page. There are also security features included on the back of SECURESTAR® official checks. Also available are checks with holograms, foil and prismatic backgrounds.

SECURESTAR® SECURITY POINTS

Visible Features Designed to Deter Fraud

- A Padlock Icon, Warning Band and Warning Backer.** A padlock symbol is printed on the face of the document, indicating that security features are listed on the back side. The Padlock Icon design is a certification mark of the Check Payment Systems Association.
- B Fourdrinier Watermark.** Actual watermark in the paper that is impossible to duplicate.
- C Micro-print Signature Line.** The words "Authorized Signature" are repeated several times in type too small for copiers to duplicate. Words become dots when duplicated.
- D High Resolution Borders or Backgrounds.** Intricate design details are difficult to accurately or cleanly reproduce on scanners or copiers.
- E Thermochromic Ink Padlock Icon on Backer.** Placing a thumb over the padlock icon for a few seconds alters the appearance of the icon (printed on back of check).
- F Guaranteed No Missing Numbers.** Assurance that all of your documents are present.

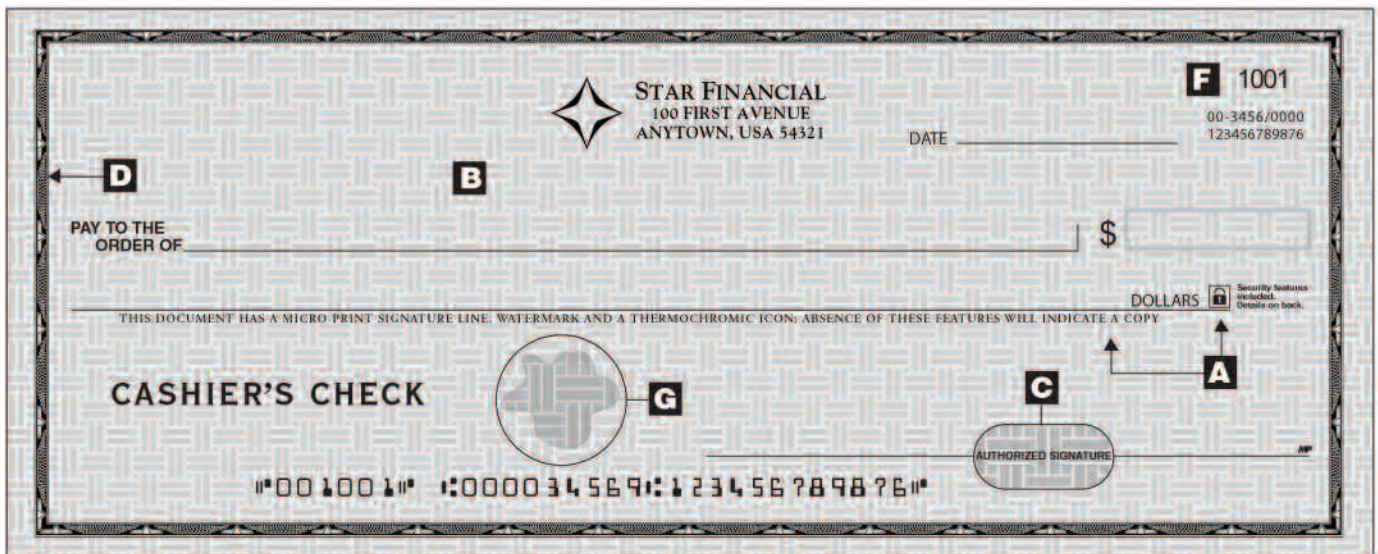

Hidden Features Designed to Enhance Check Security

- G Full Chemical Reactivity.** If chemical alteration is attempted, visible discolored blotches will appear.
- H Fluorescent Fibers.** Invisible paper fibers that fluoresce under a blacklight.
- I Securely Packaged.** As an added measure of security, all official checks are packaged with tamper-evident security seals on every box.

Standard check sizes include: Unit sets measuring 3 3/8" x 8 3/8" x 9 1/8", Laser cut sheet and continuous checks measuring 3 1/2" x 8 1/2". Custom sizes are also available, to meet customer's specific needs.

Ennis stocks a complete line of computer accessories, which are illustrated in our Supplies & Accessories Catalog. PC Cleaning Kits, Computer Cleaners and Surge Protectors are highlighted in the catalog and remain some of our best-selling computer accessories. This catalog serves as a complete selling tool for Ennis distributors through Ennis' Cooperative Marketing program. The program allows customers to personalize the brochure with their logo & company information. For more information, contact the Ennis HOTLine at (800) 972.1609.

Additional Supply & Accessory items available:

- Computer Mouse
- Organizer Stands
- Copier Supplies
(Popular names. such as Canon, Konica, Minolta, Panasonic & more)
- Stock Computer Labels
- Fax, Inkjet Laser Supplies
- Facsimile Paper Rolls
- Printer Ribbons

GENERAL INFORMATION & POLICIES

TRADE POLICY

Ennis Business Forms, Inc. (Ennis) follows normal printing industry trade customs as adopted by the Graphic Arts Council Of North America and the Printing Industries of America. Ennis operates a number of plants producing a wide variety of products. The Ennis Trade and Manufacturer's Policies listed herein are general Trade Policies. Certain Ennis plants may have additional unique job specification needs, production requirements and Trade Policies. Local Ennis plant Trade Policies are incorporated herein by this reference. Ennis is referred to herein as "Ennis" or as "Plant" and buyers of Ennis products are referred to as "Dealer".

POLICY PERTAINING TO QUOTES

A quotation not accepted by a dealer within 30 days from the date of the quote may be terminated or changed by the Plant.

ACCURACY OF SPECIFICATION

Quotations are based on the accuracy of the specifications provided by the Dealer. The plant can requote a job at the time of actual submission of the job if copy, film, tapes, disks or other input materials do not conform to the information on which the original quotation was based.

POLICY PERTAINING TO ORDERS

General

Acceptance of orders is subject to credit approval and contingencies such as fire, water, strikes, theft, vandalism, acts of God, and other causes beyond the control of the Plant. Orders canceled by the Dealer require compensation to the Plant for incurred costs and related obligations.

All orders are taken subject to Plant approval. Orders should be accompanied by a signed purchase order and should include pricing detail to support unit price or be accompanied by a copy of the Plant quotation or refer to the Plant's quotation number. Changes to orders should be made in writing. Verbal instructions must be confirmed in writing to avoid misunderstandings.

ACKNOWLEDGEMENTS

All orders for custom products will be acknowledged by the Plant. It is the dealer's responsibility to check the specifications listed on the Plant's acknowledgement against the buyer's order to insure the correctness of specifications. The Plant must be notified immediately and supplied with written confirmation of any corrections or changes.

ALTERATIONS/CONNECTIONS

Dealer alterations include all work performed in addition to original specifications. All such work will be charged at the Plant's current rates.

CAMERA-READY COPY OR NEGATIVE FURNISHED

The Plant reserves the right to decide if original art, copy, paste-up, negative or digital file is usable.

A camera-ready copy or negative allowance will be made if the copy furnished meets the following requirements:

1. The exact size of the finished form or printed document must be furnished.
2. No reduction or enlargement of the copy is permitted.
3. If alterations, corrections, or changes are to be made, the camera-ready copy or negative allowance will not apply.
4. The copy must be a repro proof, glossy or camera ready paste-up for each color.
5. The copy or negative must be furnished flat or rolled, not folded.
6. Negatives should be furnished unmasked so press registration marks may be added.
7. If the form or printed document is two or more colors, separate negatives must be provided for each color with the alignment marks clearly indicated.

If the form qualifies for camera-ready copy or negative allowance, the Plant will deduct the appropriate (per order) amount from the Basic Price. See also Shooting Copy.

CLEAR COPY

Clear hand-printed copy should be submitted when possible. When pen or pencil hand-drawn copy is supplied, exact spacing measurements must be given or copy must be mounted on appropriately ruled spacing charts showing horizontal and vertical spacing. Facsimile or photo static copy is not acceptable for spacing.

CLEAR SPECIFICATIONS

All orders must contain clear and complete specifications for construction and printing. Orders will not be processed by the Plant until copy and specifications are clear.

CREATIVE WORK

Sketches, copy, dummies and all other creative work developed or furnished by the Plant, including negatives and plates, are the Plant's exclusive property. The Plant must give written approval for all use of this work and for any derivation of ideas from it.

DEALER FURNISHED MATERIAL

Materials furnished by the Dealer, or the Dealer's suppliers, are verified at the Plant with receiving reports. The Plant bears no responsibility for discrepancies between receiving reports and actual counts. Dealer-supplied paper must be delivered according to specifications furnished by the Plant. These specifications will include correct weight, thickness, pick resistance, and other technical requirements. Artwork, computer files, color separations, special dies, tapes, disks, or other materials furnished by the Dealer must be usable by the Plant with out alteration or repair. Items not meeting this requirement will be repaired by the Dealer, or by the Plant and the Plant will invoice the Dealer at the Plant's current rates. Plant altered Dealer-furnished materials are the Dealer's property and will be returned to the Dealer at the request of the Dealer.

DEALER'S PROPERTY

The Plant will only maintain fire and extended insurance coverage on property belonging to the Dealer while the property is in the Plant's possession. The Plant's liability for this property will not exceed the amount recoverable from insurance. Additional insurance coverage may be obtained if it is requested in writing, and if the insurance premium is paid by the Dealer to the Plant.

DELIVERY

Unless otherwise specified, the price quoted is for a single shipment, without storage, F.O.B. Plant's platform or warehouse serving the manufacturing Plant. Proposals are based on continuous and uninterrupted delivery of the complete order. If the specifications state otherwise, the Plant will charge accordingly at current rates. Charges for delivery of materials and supplies from the Dealer to the Plant, or from the Dealer's supplier to the Plant, are not included in quotations unless specified. Title for finished work passes to the Dealer upon delivery to the carrier at the shipping point; or upon mailing of invoice(s) for the finished work or its segments, whichever occurs first.

ELECTRONIC MANUSCRIPT, IMAGE, OR DIGITAL FILE

It is the Dealer's responsibility to maintain a copy of the original computer file. The Plant is not responsible for accidental damage to media supplied by the Dealer or for the accuracy of the furnished input or final output. Until digital input can be evaluated by the Plant, no claims or promises are made about the Plant's ability to work with jobs submitted in digital format, and no liability is assumed for problems that may arise. Any additional translating, editing, or programming needed to utilize Dealer-supplied computer files will be charged at the Plant's prevailing rates.

EXPERIMENTAL WORK

Experimental or preliminary work performed at the Dealer's request will be billed to the Dealer at the Plant's current rates. This work cannot be used without the Plant's written consent.

FORM SIZE

The width of a form is measured as follows:

- Books and Guest Checks – parallel to binding stub.
- Continuous Forms – at right angles to the marginal line hole punching and including both margins.
- Register Forms – side to side (parallel to in-between set perforations).
- Snap-A-Part Unit Sets – parallel to stub perforation.
- Tags, Single – the punch and / or patch end.
- Tags, Manifold – parallel to the glued perforation.
- Tags, Continuous – at right angles to the marginal hole punching.

INTERMEDIATE MATERIALS

The Plant will retain intermediate materials until the related end product has been accepted by the Dealer. If requested by the Dealer, intermediate materials will be stored for an additional period at an additional charge. The Plant is not liable for any loss or damage to stored material beyond what is recoverable by the Plant's fire and extended insurance coverage.

OUTSIDE PURCHASES

Unless otherwise agreed in writing, all outside purchases as requested or authorized by the Dealer, are chargeable by the Plant to the Dealer.

OVER-RUNS OR UNDER-RUNS

Over-runs or under-runs will not exceed 10% of the quantity ordered. The Plant will bill for the actual quantity delivered within this tolerance. If the Dealer requires a guaranteed quantity, the percentage of tolerance must be stated at the time of quotation.

In the event the Dealer requires a guaranteed quantity, the Plant will add an up-charge to compensate the Plant for related wastage. The "Guaranteed Quantity" up-charge will be specified by the Plant when the job is quoted.

The up-charge for "Guaranteed Quantity" is required because of collator and other bindery or finishing wastage. The press must over-run each part of a job in order to provide an adequate supply of each part for collator set-up and run wastage. In addition, bindery and other finishing operations will also incur wastage in the course of set-up and run.

PREPAID SHIPMENTS

Prepaid shipments require that the Dealer specify one of the following prepayment methods:

1. The shipment will be made prepaid with the freight charges added to the invoice.
2. The shipment will be made prepaid with the freight charges billed direct to the Dealer by the freight line.

If the Plant receives no instructions, the Plant will handle prepaid shipments in accordance with Item #1 above.

PREPARATORY MATERIALS

Artwork, type, plates, negatives, positives, tapes, disks, digital files and all other items supplied by the Plant remain the Plant's exclusive property.

Preparatory Materials supplied by the Dealer for the production of custom printed products will be returned upon request. Preparatory Materials, provided by the Plant or the Dealer, for imprinted products are destroyed and cannot be returned.

PRINTING AREA AND LOCK-UP SPACE

If printing must bleed, or does not allow at least 1/2" for lock-up space, contact the Plant's Customer Service Department for a special estimate.

PRODUCTION SCHEDULES

Production schedules will be established and followed by both the Dealer and the Plant. In the event that the Dealer does not adhere to production schedules, delivery dates will be subject to renegotiations. There will be no liability or penalty for delays due to state of war, riot, civil disorder, fire, strikes, accidents, action of government or civil authority, acts of God, or other causes beyond the control of the Plant. In such cases, schedules will be extended by an amount of time equal to the delay incurred.

PROOFS-COLOR

Because of differences in equipment, paper inks, and other conditions between color proofing and production pressroom operations, a reasonable variation in color between color proofs and the completed job is to be expected. When variations of this kind occur, the Plant will consider it acceptable performance. The Plant shall be sole determinant of the reasonableness of variation.

PROOFS-PREPRESS

The Plant will submit prepress proofs along with original copy for the Dealer's review and approval. Proofs and any corrections will be returned to the Plant on a "master set" marked "OK", "OK with corrections", or "Revised proof required" and will be signed by the Dealer. Until the "master set" is received, no additional work will be performed. The Plant will not be responsible for undetected production errors if:

1. Proofs are not required by the Dealer.
2. Job is printed per the Dealer's "OK".
3. Requests for changes are communicated orally.

PROOFS-PRESS

Press proofs will not be furnished unless they have been required in writing in the Plant's quotation. A press sheet can be submitted for the Dealer's approval as long as the Dealer is present at the press during make-ready. Any press time lost or alterations/ corrections made because of the Dealer's delay or change of mind will be charged at the Plant's current rates.

RIGHTS TO PROMOTE

The Plant reserves the right to use all products produced by the Plant in the Plant's advertising, promotional literature, or other displays and sample programs unless instructed otherwise in writing by the Dealer at the time of the order.

SAMPLES

Samples of each custom printed order will be mailed to the Dealer with the Plant's invoice.

SHOOTING COPY

The Plant reserves the right to decide if a previously produced document (ie., an existing printed document) is useable as copy.

Previously produced forms and other printed documents can be used as camera-ready copy if the form or document is received by the Plant:

1. Protected by cardboard.
2. Not folded or stapled.
3. With dark ink, black or red preferred.
4. Printed on white paper.
5. With carbon removed or chemical carbonless sets interleaved to prevent smudges.
6. With no screens or process color involved.
7. With 1/2" lock-up space.
8. With printing in stub arranged to miss line holes, perforations, folds and staples.
9. With no changes required in copy.

If the form qualifies as a previously produced form or document, the Plant will deduct the appropriate (per order) amount from the basic price.

STORAGE OF JOBS

Contact the Plants Customer Service Department.

TAXES

All amounts due for taxes and assessments will be added to the Dealer's invoice and are the responsibility of the Dealer. No tax exemption will be granted unless the Dealer's "Exemption Certificate" (or other official proof of exemption) accompanies the Dealer's purchase order or is currently on file at the Plant. If, after the Dealer has paid the invoice, it is determined that more tax is due, then the Dealer must promptly remit the required taxes to the taxing authority, or immediately reimburse the Plant for any additional taxes paid.

TRANSPORTATION

Orders should state the method of shipping, e.g., Truck, UPS, etc. When not indicated, the Plant will ship "Best Way." Orders will be shipped complete when manufactured. Orders picked up by the Dealer, his customer, agent, or given to a common carrier by the Plant constitutes delivery, transfer of title, and possession to the Dealer. Claims for damaged shipments should be filed against the carrier making delivery. The Plant is not responsible for goods damaged, lost, or delayed in shipment.

Shipment will be made in the Dealer's name, direct to the Dealer freight prepaid, unless otherwise specified on Dealer's order.

Special Considerations:

1. Inside Delivery
(Truck lines are not required to do inside delivery & use stairways. Elevators must be provided for inside delivery.)
2. Rush Deliveries
(Available upon request – Contact the Plant's Customer Service Department.)
3. Charges for Taking Forms to an Airport or Bus
(Contact the Plant's Customer Service Department for charges. Charges vary by plant.)
4. Bill of Lading Class
(The Plant's products will normally ship Class 55 for LTL.)

POLICY PERTAINING TO ORDERS

COMPATIBLE NEGATIVE PROGRAM

If the dealer sells software compatible forms, or custom printed documents, to several customers, all of which use the same software system or basic document, the plant will keep the Dealer's base negative on file allowing the Dealer to combine future custom headings with the base negative.

DEALER CREDIT

Approval from the Ennis Finance Department is required for an open account. The Ennis Dealer Application Form should be submitted as soon as possible so that the Dealer's first order can be processed without delay.

Credit information is maintained within Ennis, Texas. The Ennis Customer Finance Department staff has been trained to serve Dealer needs and are willing to work with a Dealer if a problem should arise. Do not hesitate to call Customer Finance.

REORDER ALLOWANCE

A reorder allowance will be allowed for customer forms if the change in composition from the previous order does not exceed a change in form number, printing date, address, and/or telephone number. The form must have been printed by the Plant within the last 24 months. Please provide the previous order number when placing a repeat order.

Policy varies for all other products. Check with the Plant's Customer Service Department for policy on other products.

SPECIAL PRICING OR IMPROVED DELIVERY

Contact the Plant's Customer Service Department.

TELECOMMUNICATION

Unless otherwise agreed, the Dealer will pay for all transmission charges. The Plant is not responsible for any errors, omissions, or extra costs resulting from faults in the transmission.

Note: All Ennis plants have toll free telephone numbers for voice and FAX transmissions. In addition, Ennis provides electronic file transfer capability using the Internet (<http://www.ennis.com>). Certain plants maintain a plant specific BBS. Ask the Plant's Customer Service Department for information. See also Electronic Manuscript, Image or Digital File, page 6.

TERMS/ CLAIMS/ LIENS/DELIVERY

The payment terms are 1% 10 Days Proximo, Net 30.

FREIGHT TERMS ARE F.O.B. PLANT

Claims for defects, damages, or shortages must be made by the Dealer in writing no later than 10 calendar days after delivery. If no such claim is made, the Plant and the Dealer will understand that the job has been accepted. By accepting the job, the Dealer acknowledges that the Plant's performance has fully satisfied all terms, conditions, and specifications. The Plant's liability will be limited to the quoted selling price of affected goods, without additional liability for special or consequential damages. All complaints must be made in writing and must be addressed to the Customer Service Department at the Plant of manufacture. The information required will include: the Plant invoice number, production job number, type of product, client name and shipment date. A request for return forms must be addressed to the plant of manufacturer's Department. Please do not return forms without written permission.

As security for payment of any sum due under the terms of an agreement, the Plant has the right to hold and place a lien on all Dealer property in the Plant's possession. This right applies even if credit has been extended, notes have been accepted, trade acceptances have been made, or payment has been guaranteed. If payment is not made, the Dealer is liable for all collection costs incurred.

LIABILITY

1. **Disclaimer of Express Warranties:** The Plant warrants that the work is as described in the Dealer's purchase order. The Dealer understands that all sketches, copy, dummies, and preparatory work shown to the dealer are intended only to illustrate the general type and quality of the work. They are not intended to represent the actual work performed.
2. **Disclaimer of Implied Warranties:** The Plant warrants only that the work will conform to the description contained in the Dealer's purchase order. The Plant's maximum liability, whether by negligence, contract, or otherwise, will not exceed the return of the amount invoiced for the work in dispute. Under no circumstances will the Plant be liable for specific, individual, or consequential damages.

INDEMNIFICATION

The Dealer agrees to protect the Plant from economic loss and any other harmful consequences that could arise in connection with the work. This means that the Dealer will hold the Plant harmless and save, indemnify, and otherwise defend the Plant against claims, demands, actions, and proceedings on any and all grounds. This will apply regardless of responsibility for negligence.

1. **Copyrights** – The Dealer also warrants that the subject matter to be printed is not copyrighted by a third party. The Dealer also recognizes that because subject matter does not have to bear a copyright notice in order to be protected by copyright law, absence of such notice does not necessarily assure a right to reproduce. To support these warranties, the Dealer agrees to indemnify and hold the Plant harmless for all liability, damages, and attorney fees that may be incurred in any legal action connected with copyright infringement involving the work produced or provided.
2. **Personal or Economic Rights** – The Dealer also warrants that the work does not contain anything that is libelous or scandalous, or anything that threatens anyone's privacy or other personal or economic rights. The Dealer will, at the Dealer's sole expense, promptly and thoroughly defend the Plant in all legal actions on these grounds as long as the Plant:
 - A. Promptly notifies the Dealer of the legal action.
 - B. Gives the Dealer reasonable time to undertake and conduct a defense.
3. **Refusal to Print** – The Plant reserves the right to use the Plant's sole discretion in refusing to print anything the Plant deems illegal, libelous, scandalous, improper, or infringing upon copyright law.